

## MP105E M-232 Linear Actuator User Manual

Version: 1.2

Date: 31.08.2020



This document describes the following high-resolution linear actuators with limit switches:

- **M-232.17**  
DC Drive, Travel Range 17 mm
- **M-232.17S**  
Stepper Motor Drive, Travel Range 17 mm



Physik Instrumente (PI) GmbH & Co. KG is the owner of the following trademarks:  
PI®, PIC®, PICMA®, PLine®, PIFOC®, PiezoWalk®, NEXACT®, NEXLINE®,  
NanoCube®, NanoAutomation®, Picoactuator®, PInano®

© 2020 Physik Instrumente (PI) GmbH & Co. KG, Karlsruhe, Deutschland. The text, photographs and drawings in this manual are protected by copyright. With regard thereto, Physik Instrumente (PI) GmbH & Co. KG retains all the rights. Use of said text, photographs and drawings is permitted only in part and only upon citation of the source.

Original instructions

Document number: MP105E, MMA, Version 1.2

Subject to change without notice. This manual is superseded by any new release. The latest release is available for download on our website (<http://www.pi.ws>).

# Contents

<b>1</b>	<b>About this Document</b>	<b>1</b>
1.1	Goal and Target Audience of this Manual .....	1
1.2	Symbols and Typographic Conventions.....	1
1.3	Other Applicable Documents.....	2
<b>2</b>	<b>Safety</b>	<b>3</b>
2.1	Intended Use .....	3
2.2	General Safety Instructions .....	3
2.2.1	Organizational Measures.....	3
2.2.2	Safety Measures during Installation .....	4
2.2.3	Safety Measures during Start-Up .....	5
2.2.4	Safety Measures during Operation.....	5
2.2.5	Safety Measures during Maintenance .....	6
<b>3</b>	<b>Product Description</b>	<b>7</b>
3.1	System Overview.....	8
3.2	Features and Applications .....	9
3.3	Model Overview .....	10
3.4	Product View.....	11
3.5	Scope of Delivery .....	11
3.6	Suitable Controllers .....	12
3.7	Accessories .....	12
3.8	Technical Features .....	12
3.8.1	Rotary Encoder.....	12
3.8.2	Limit Switches.....	12
<b>4</b>	<b>Unpacking</b>	<b>13</b>
<b>5</b>	<b>Installation</b>	<b>15</b>
5.1	General Notes on Installation .....	15
5.2	Installing the Actuator in a Mechanical Mounting .....	16
5.2.1	Providing a Suitable Mechanical Mounting and Installation Environment.....	17
5.2.2	Installing the Actuator in a Mechanical Mounting .....	19
5.3	Installing the Actuator in a Micropositioning Stage.....	21

6	Start-Up	27
6.1	General Notes on Start-Up .....	27
6.2	Starting Up the Actuator .....	29
6.2.1	M-232 Entries in the Stage Database of PI .....	31
7	Maintenance	33
7.1	General Notes on Maintenance .....	33
7.2	Lubricating the M-232 .....	33
7.3	Cleaning the M-232 .....	34
8	Troubleshooting	35
9	Customer Service	37
10	Technical Data	39
10.1	Specifications .....	39
10.1.1	Data Table .....	39
10.1.2	Ambient Conditions and Classifications .....	40
10.1.3	Limit Switch Specifications .....	41
10.2	Dimensions .....	42
10.3	Pin Assignment .....	43
10.3.1	Model with DC Gear Motor .....	43
10.3.2	Model with Stepper Motor .....	44
11	Old Equipment Disposal	45
12	EC Declaration of Conformity	47

# 1 About this Document

## 1.1 Goal and Target Audience of this Manual

This manual contains information on the intended use of the M-232.

It assumes that the reader has a fundamental understanding of basic servo systems as well as motion control concepts and applicable safety procedures.

For updated releases of this user manual, or if you have any questions, contact our customer service department (p. 37).

## 1.2 Symbols and Typographic Conventions

The following symbols and typographic conventions are used in this user manual:

### **CAUTION**



#### **Dangerous situation**

If not avoided, the dangerous situation will result in minor injury.

- Actions to take to avoid the situation.

### **NOTICE**



#### **Dangerous situation**

If not avoided, the dangerous situation will result in damage to the equipment.

- Actions to take to avoid the situation.

### **INFORMATION**

Information for easier handling, tricks, tips, etc.

Symbol	Meaning
--------	---------

Symbol	Meaning
1. 2.	Action consisting of several steps whose sequential order must be observed
➤	Action consisting of one or several steps whose sequential order is irrelevant
▪	List item
p. 5	Cross-reference to page 5
RS-232	Labeling of an operating element on the product (example: socket of the RS-232 interface)

### 1.3 Other Applicable Documents

The devices and software tools which are mentioned in this documentation are described in their own manuals.

For the latest versions of the user manuals contact our customer service department (p. 37).

Product	Document
Linear actuators	MP122EK Short Instructions
Suitable Controller	User Manual of the applied controller

## 2 Safety

### 2.1 Intended Use

The M-232 is a laboratory device as defined by DIN EN 61010-1. It is intended to be used in interior spaces and in an environment which is free of dirt, oil, and lubricants.

Based on its design and realization, the M-232 is intended for positioning, adjusting and shifting loads in one axis at various velocities.

The intended use of the M-232 is only possible when installed and with a suitable controller (p. 12). The controller is not included in the scope of delivery of the M-232.

### 2.2 General Safety Instructions

The M-232 is built according to state-of-the-art technology and recognized safety standards. Improper use can result in personal injury and/or damage to the M-232.

- Only use the M-232 for its intended purpose, and only use it if it is in a good working order.
- Read the user manual.
- Immediately eliminate any faults and malfunctions that are likely to affect safety.

The operator is responsible for the correct installation and operation of the M-232.

#### 2.2.1 Organizational Measures

##### User manual

- Always keep this user manual next to the M-232.  
If the user manual is lost or damaged, contact our customer service department (p. 37).
- Add all information given by the manufacturer to the user manual, for example supplements or Technical Notes.

- If you pass the M-232 on to other users, also turn over this user manual as well as all other relevant information provided by the manufacturer.
- Only use the device on the basis of the complete user manual. Missing information due to an incomplete user manual can lead to slight injury as well as property damage.
- Only install and operate the M-232 after having read and understood this user manual.

### **Personnel qualification**

The M-232 may only be started up, operated, maintained and cleaned by authorized and qualified staff.

## **2.2.2 Safety Measures during Installation**

A cable break leads to a failure of the linear actuator.

- Install the linear actuator so that the cable is not bent or squeezed too severely during operation.

Lateral forces that affect the pusher of the linear actuator increase the friction on the internal drive components. Increased friction impairs the motion of the pusher and increases wear on the drive components.

- Avoid lateral forces on the pusher of the M-232.

Overtightening the mounting screws can damage the mounting shaft of the linear actuator and hinder the motion of the pusher. This reduces the positioning accuracy.

- Tighten the mounting screws to a maximum torque of 0.3 Nm.

The heat produced during operation of the M-232 can affect your application.

- Install the M-232 so that your application is not affected by the dissipating heat.



### 2.2.3 Safety Measures during Start-Up

A motorized linear actuator can generate powerful forces depending on the gear ratio.

Connecting a linear actuator to an unsuitable controller can cause damage to the linear actuator or controller.

- Connect a linear actuator with DC motor to a DC motor controller only.
- Connect a linear actuator with stepper motor to a stepper motor controller only.

Faulty motor controllers can cause unintentional motor motion and run the M-232 into the hard stop.

The linear actuator can perform an unintentional motion when connecting it to the motor controller.

- Do not place any objects in areas where they can get caught by moving parts.
- Keep your fingers at a safe distance from the motion range of the M-232.

The collision of moving parts with the hard stop (end of travel range), as well as high acceleration, can cause damage to, or considerable wear on the mechanical system.

- In the event of a malfunction of the motor controller, stop the motion immediately.
- Ensure that the end of the travel range is approached at low velocity.
- Set your control signal so that the moving part does not stop abruptly or try to continue moving at the end of the travel range.
- Determine the maximum velocity for your application.
- Ensure that the automatic limit switch halt is supported by the controller, or that it is activated in the controller.

### 2.2.4 Safety Measures during Operation

For models with DC motors:

Unsuitable settings made to the servo-control parameters can impair the performance of the M-232. The consequences of this can be expressed as follows:

- Oscillations
- Imprecise approach of the position
- Settling time is too long
- If the performance of the M-232 is not satisfactory, check the settings for the servo-control parameters of your controller.

### **2.2.5 Safety Measures during Maintenance**

The M-232 is precisely aligned.

- Do not loosen any sealed screw.

## **3 Product Description**

### 3.1 System Overview

The following figure shows an overview of the total system.

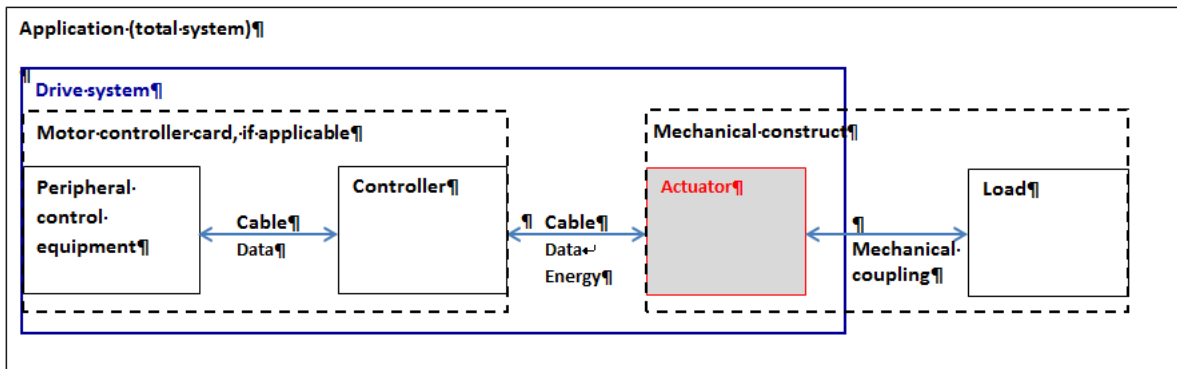

Figure 1: Overall system, overview

To operate the actuator in your application, the following components are necessary:

Component	Task	Supplied by or available from PI
Peripheral control equipment	Loads configurations and control commands to the controller (e.g. PC in connection with PC software).	PC software (e.g. PIMikroMove) included in the scope of delivery of PI controllers.
Controller	Controls the motions of the actuator.	Stand-alone device or motor controller card (PC add-on card). Available separately, see section "Suitable Controllers" (p. 12).
Actuator	Produces the motions of the part to be driven or the load in your application.	Here: linear actuator, type M-232. Present product.

Component	Task	Supplied by or available from PI
Cables	<ul style="list-style-type: none"> <li>▪ Peripheral control equipment to controller: Ensures the data communication.</li> <li>▪ Controller to actuator: Ensures the data communication and the power source of the actuator.</li> </ul>	<ul style="list-style-type: none"> <li>▪ Transmission cable between PC and controller. Included in the scope of delivery of PI controllers.</li> <li>▪ Transmission cable between controller and actuator: Part of the actuator or included in the scope of delivery of the piezo actuator.</li> </ul>
Mechanical structure	Ensures among other things the secure fixation of the actuator and thus a high repeatability.	Only mounting nut (for mechanical connection) included in the scope of delivery of the actuator.
Mechanical coupling	Establishes the connection between the actuator and the load (pusher with a separate end piece, depending on the model).	Also in case exchangeable parts can be used, all options are included in the scope of delivery of the actuator (e.g. end pieces).
Load	Part to be driven. This is to be moved in your application.	-

If a motor controller card is used, the "controller" component and the connection between the peripheral control equipment and the controller ("cable") are physically inside of the PC.

## 3.2 Features and Applications

The M-232 is a compact and cost-effective linear actuator with a 17 mm travel range and a length that could be reduced with a folded drive to only 72 mm. As a result of the combination of a backlash-free preloaded DC gear motor with high-resolution rotary encoder and an extremely low-friction and zero-backlash design, the M-232 achieves minimum incremental motions of 100 nm and velocities of up to 2.5 mm/s. A design with a stepper motor is also on offer.

Integrated limit switches as well as line drivers enable easy installation in automation solutions and protect the mechanical system of the actuator.

The M-232 can be installed, for example, on the fiber positioning system / micropositioning stage M-105 or M-106 instead of a micrometer screw or a piezo drive.

### 3.3 Model Overview

Two versions of the M-232 are available. They differ in terms of their drive type.

<b>Model</b>	<b>Name</b>
<b>M-232.17</b>	Compact High-Resolution DC Mike Linear Actuator, 17 mm, Limit Switches
<b>M-232.17S</b>	Compact High-Resolution Stepper Mike Linear Actuator, 17 mm, Limit Switches

- For further technical data, see the specifications (p. 39).

PI also produces custom designs upon request. Custom designs can differ from the described standard products in respect to dimensions, characteristics or other technical data.

- If necessary, contact our customer service department (p. 37) directly.

### 3.4 Product View

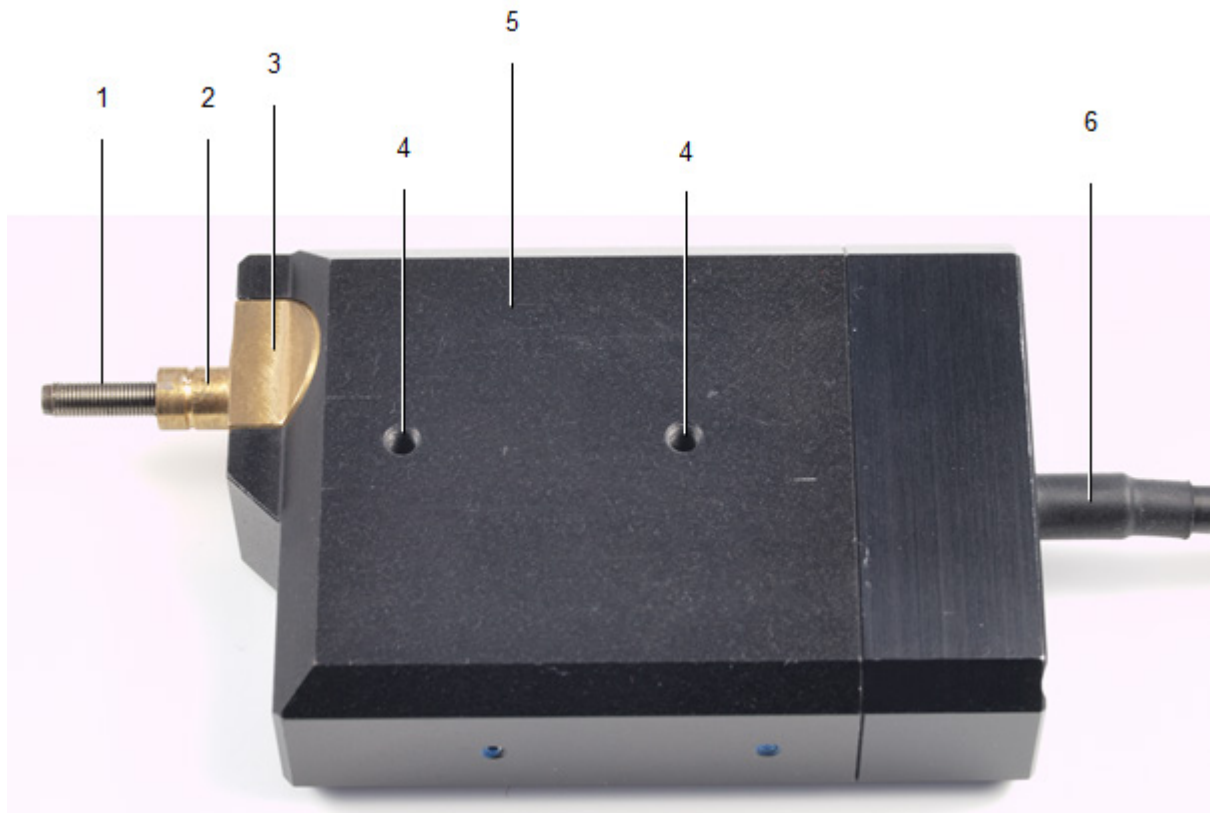

Figure 2: Product view

- 1 Moving pusher, rotating, with M3.5 thread and convex end
- 2 Mounting shaft with circumferential groove
- 3 Locating surface
- 4 Continuous mounting hole, M3 thread
- 5 Case
- 6 Cable for connecting to the controller

### 3.5 Scope of Delivery

Order Number	Items
M-232	Linear actuator according to order (p. 10)
MP122EK	Short Instructions

## 3.6 Suitable Controllers

The M-232 must be connected to a suitable controller (see Data Table, p. 39).

The required PC software is included in the scope of delivery of the PI controllers. The operation of the controllers is described in the corresponding user manuals.

## 3.7 Accessories

Order Number	Description
C-842.AP1	PWM-to-analog adapter box for operating M-232 linear actuators with PWM signals

To order, contact our customer service department (p. 37).

## 3.8 Technical Features

### 3.8.1 Rotary Encoder

The models with DC motors are equipped with a rotary encoder. A rotary encoder, also called an incremental or incremental rotary encoder, is implemented at a rotating point in the drivetrain, e.g. the motor shaft. To determine the relative position, the controller counts the encoder signals, the so-called impulses.

### 3.8.2 Limit Switches

The M-232 is equipped with non-contact, Hall-effect limit switches.

Each limit switch sends an overtravel signal on a dedicated line to the controller. The controller then stops the motion. If the controller does not stop the motion in time, the linear actuator runs into the hard stop.

See "Limit Switch Specifications" (p. 41) for more information.



## 4 Unpacking

1. Unpack the M-232 with care.
2. Compare the contents against the items covered by the contract and against the packing list.
3. Inspect the contents for signs of damage. If parts are missing or you notice signs of damage, contact PI immediately.
4. Keep all packaging materials in case the product needs to be returned.



## 5 Installation

### 5.1 General Notes on Installation

#### NOTICE

**Cable break!**

A cable break leads to a failure of the linear actuator.

- Install the linear actuator so that the cable is not bent or squeezed too severely during operation.

#### NOTICE

**Increased friction!**

Lateral forces that affect the pusher of the linear actuator increase the friction on the internal drive components. Increased friction impairs the motion of the pusher and increases wear on the drive components.

- Avoid lateral forces on the pusher of the M-232.

#### NOTICE

**Heating up of the M-232 during operation!**

The heat produced during operation of the M-232 can affect your application.

- Install the M-232 so that your application is not affected by the dissipating heat.

#### INFORMATION

Linear actuators with DC gear motors are equipped with integrated signal drivers for cable lengths of  $\leq 10$  m between linear actuator and motor controller.

#### INFORMATION

The M-232 is suitable for installation in the following fixtures:

- Suitable mechanical mounting
- PI micropositioning stages / fiber positioning systems of the types M-105 and M-106

The necessary steps are described in the following sections.

---

### **INFORMATION**

To achieve an optimum repeatability, the mounting shaft must not have any backlash.

- During mounting, make sure that there is a faultless connection between the actuator and the mechanical mounting.
- 

## **5.2 Installing the Actuator in a Mechanical Mounting**

To install the actuator in a mechanical mounting, the following steps are required:

1. Providing a suitable mechanical mounting
2. Installing the actuator in the mechanical mounting

Detailed instructions can be found in the following sections.

### 5.2.1 Providing a Suitable Mechanical Mounting and Installation Environment

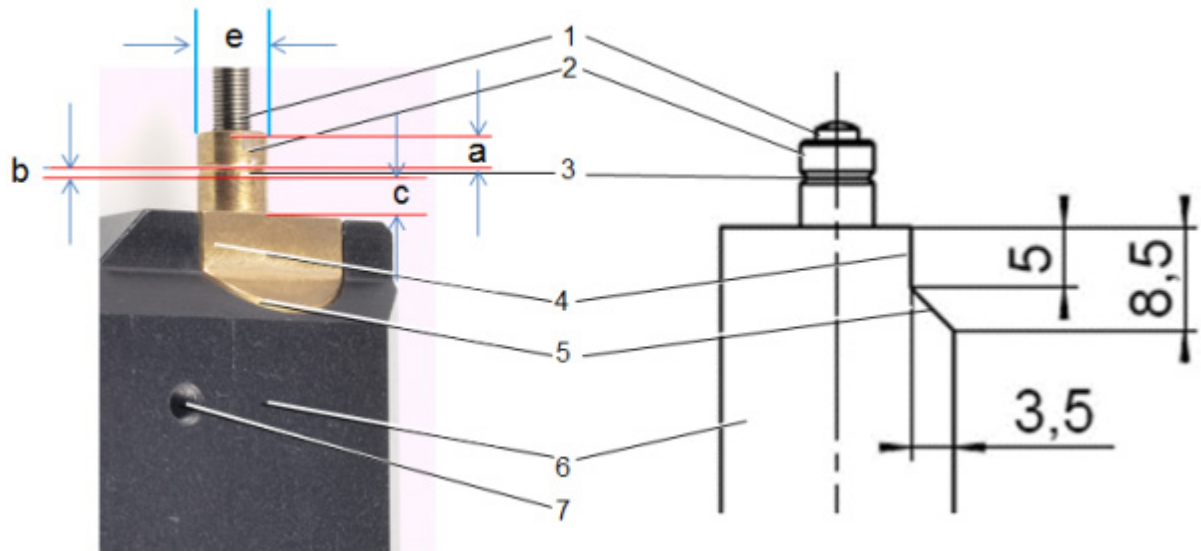

Figure 3: Components, installation dimensions (in mm)

- 1 Pusher, rotating, with M3.5 thread and R3 convex end
- 2 Mounting shaft with width (a): 2.5 mm width (c) 3.5 mm diameter (e): 6 mm
- 3 Circumferential groove for mounting a mounting screw, V profile with width (b): 1 mm angle to the vertical axis:  $\pm 45^\circ$
- 4 Locating surface  
For dimensions, see sectional view on the right (relevant e.g. for installation in M-105)
- 5 Slant  
For dimensions, see the sectional view on the right
- 6 Case
- 7 Continuous mounting hole, M3 thread

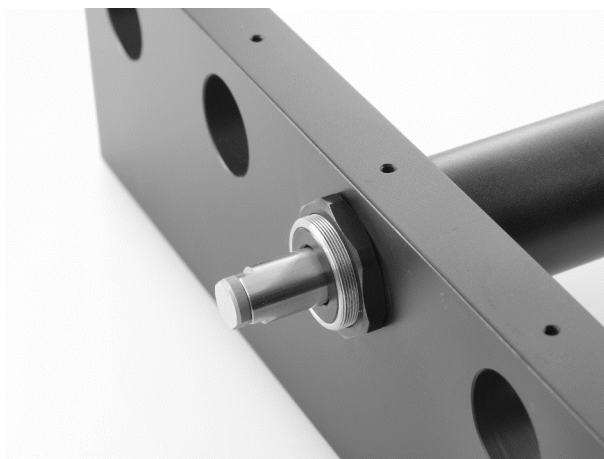

Figure 4: Example for the installation of a linear actuator (here: an M-235)

A suitable mechanical mounting and installation environment are necessary for the proper use of the actuator.

- Make sure that the following conditions have been met:
  - Material and statics of the mounting are designed so that the static and dynamic forces that occur can be safely and continuously managed.
  - The dimensions of the mounting have been adjusted to the dimensions of the actuator (see above figures and dimensions (p. 42)), especially to the following specifications:
    - Diameter of the mounting shaft
    - Slant and locating surface if a positive connection is planned
    - Position of the circumferential groove if a fixation with engaging mounting screws is planned
  - The intended motions of the pusher and the load must not be inhibited by the dimensions of the installation environment.
- Take into account the following specifications when planning the application and installing the actuator:
  - Travel range: max. 17 mm
  - Space requirements for a kink-free and proper guiding of the connection cable and motor cable if necessary
  - Length of the connection cable (approx. 0.5 m) and additional motor cables (3 m or 10 m)

- Avoid or label danger areas that result from the installation of the actuator and from use, in accordance with the legal regulations (e.g. risk of crushing in the case of heavy moving loads, fast actuator motions and/or high drive torques).
- Check whether the limit switches (for a pusher displacement of 0 mm or 17 mm) can be reached with the planned design of your application.
- If the limit switches of the actuator cannot be reached with the planned minimum and maximum displacements: Make sure that the actuator and the load **only move within the planned range**. Suitable measures:
  - Corresponding programming of the controller
  - Emergency off switch
  - Automatic shutdown systems

The complete dimensions of the actuator and relevant individual parts can be found in the figures in the section Dimensions (p. 42).

## 5.2.2 Installing the Actuator in a Mechanical Mounting

### NOTICE



#### Overtightened mounting screws!

Overtightening the mounting screws can damage the mounting shaft of the linear actuator and hinder the motion of the pusher. This reduces the positioning accuracy.

- Tighten the mounting screws to a maximum torque of 0.3 Nm.

### INFORMATION

Two continuous mounting holes with M3 thread are present in the case of the linear actuator, see the figures in "Product View (p. 11)" or "Providing a Suitable Mechanical Mounting and Installation Environment (p. 16)". These holes can be used alternatively or in addition to the procedure shown here for installing the actuator.

- See the dimensional drawing (p. 42) for the position of the continuous mounting holes.

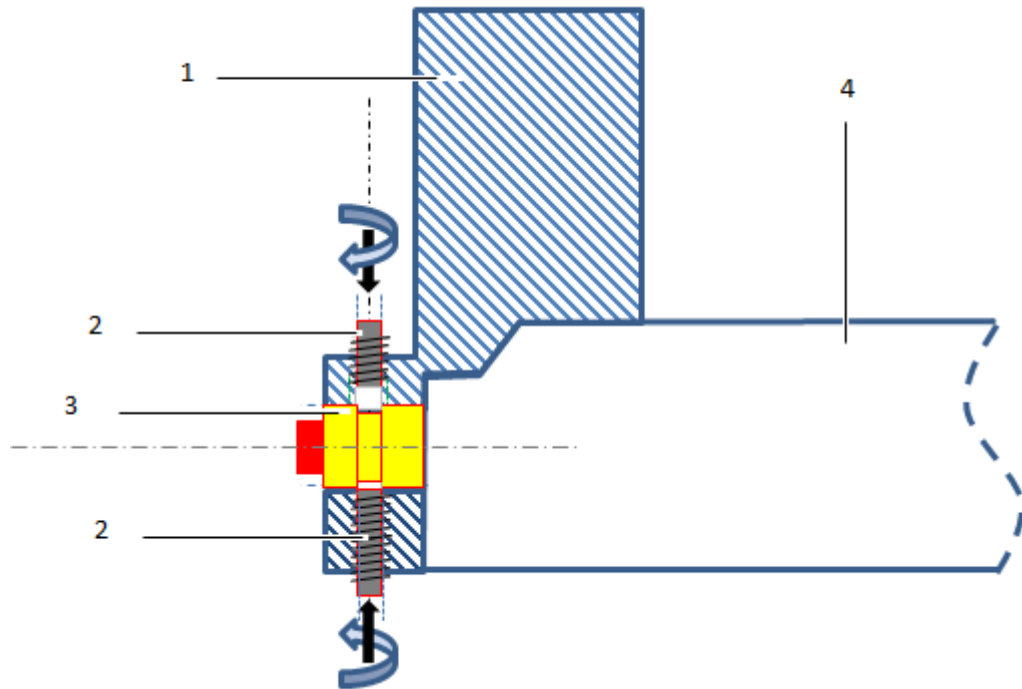

Figure 5: Example for the installation in a mechanical mounting, sectional view

- 1 Mechanical Mounting
- 2 Mounting screw (e.g. M2 grub screw)
- 3 Mounting shaft with circumferential groove
- 4 Sleeve / case of the actuator

We recommend fixing the actuator with at least one mounting screw, which is screwed into each mechanical mounting and engages in the groove of the mounting shaft. The following instructions apply to this case.

- If you use other designs, proceed correspondingly.

### Prerequisites

- ✓ You have read and understood the General Notes on Installation (p. 15).
- ✓ You have provided your application with a suitable mounting for the mounting shaft of the linear actuator in accordance with the instructions of the previous section.



- ✓ You have made a suitable hole with internal thread in the mechanical mounting for each of the planned mounting screws. The hole is positioned so that the mounting screw can engage vertically in the circumferential groove of the mounting shaft after installation. The position of the circumferential groove can be found in the above illustration of the components and installation dimensions.

### Tools and accessories

- At least one suitable mounting screw, e.g. M2 grub screw. To be able to engage in the groove optimally, the screw should have an angled end instead of a flat end.
- Suitable Allen wrench or screwdriver for the mounting screw(s).

### Installing the actuator in a mechanical mounting

1. Insert the actuator in the mounting of your application.
2. Place the groove of the mounting shaft precisely across the holes for mounting screws.
3. Screw all mounting screws into the threaded hole of the mounting with a maximum torque of 0.3 Nm each time until you feel resistance.
4. Check that the actuator is correctly fitted in the mounting.

## 5.3 Installing the Actuator in a Micropositioning Stage

The M-232 is suitable, e.g., for installation in a PI micropositioning stage / -fiber positioning system of the type M-105 or M-106.

### NOTICE



#### Overtightened mounting screws!

Overtightening the mounting screws can damage the mounting shaft of the linear actuator and hinder the motion of the pusher. This reduces the positioning accuracy.

- Tighten the mounting screws to a maximum torque of 0.3 Nm.

### Prerequisites

- ✓ You have read and understood the General Notes on Installation (p. 15).
- ✓ If necessary: you have disassembled the drive of the micropositioning stage (e.g. micrometer screw or piezo drive).

### Tools and accessories

- AF 1.5 Allen wrench for M2 grub screw or corresponding screwdriver
- Micropositioning stage with suitable mounting for the linear actuator.

### Installing the actuator in a micropositioning stage

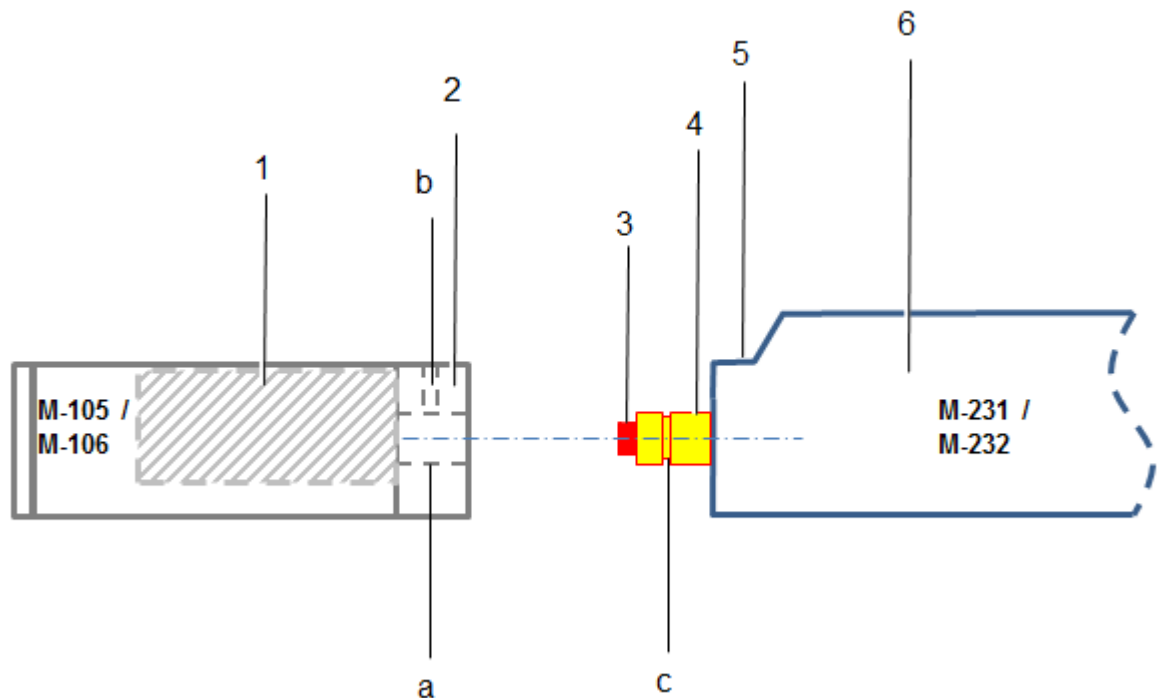

Figure 6: Actuator and stage, schematic

- 1 Moving platform (internal)
- 2 (Wide) micropositioning stage front with  
(a) horizontal hole  
(b) vertical threaded hole with grub screw
- 3 Pusher
- 4 Mounting shaft with  
(c) groove
- 5 Locating surface
- 6 Sleeve / case

1. If possible, place the micropositioning stage on a level surface. The moving platform must be visible from above.

2. Unscrew the grub screw in the middle of the front of the micropositioning stage by around three rotations using an Allen wrench or screwdriver.

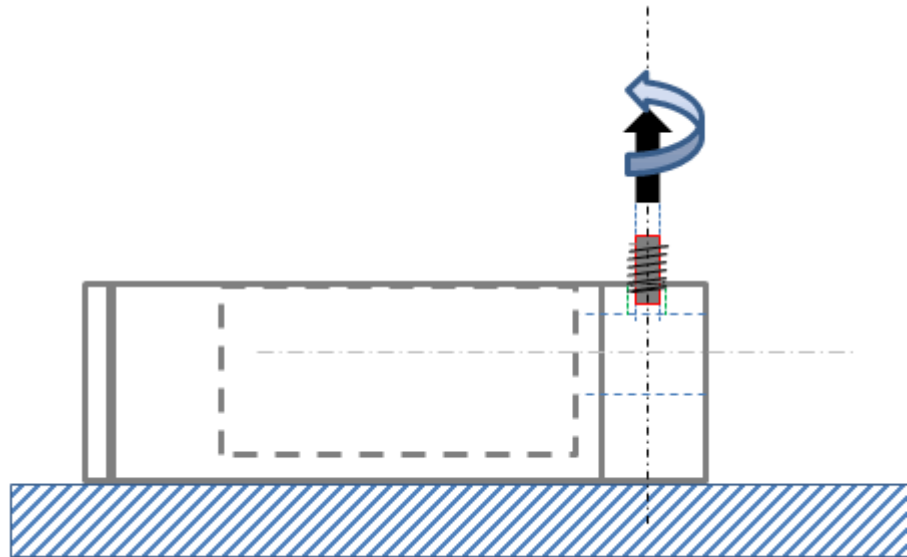

Figure 7: Unscrew the grub screw slightly

3. Align the actuator so that the following conditions are met:
  - The locating face of the actuator is level with the top edge of the micropositioning stage.
  - The mounting shaft is located precisely across from the horizontal hole on the front of the micropositioning stage.

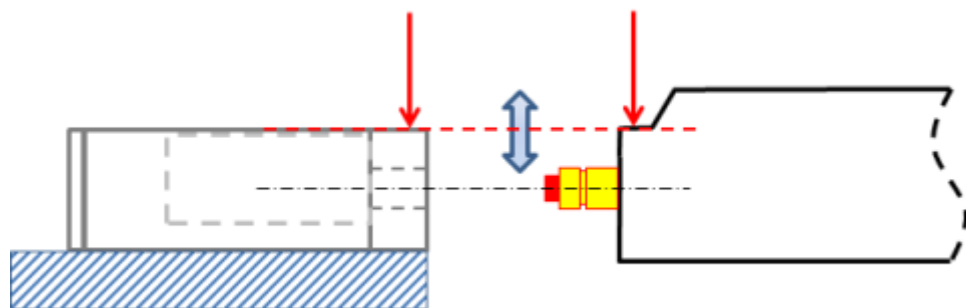

Figure 8: Aligning the actuator

4. Insert the mounting shaft of the actuator into the horizontal hole on the front of the micropositioning stage until the locating surface of the actuator and the front of the micropositioning stage touch. The grub screw is then precisely above the circumferential groove of the mounting shaft.

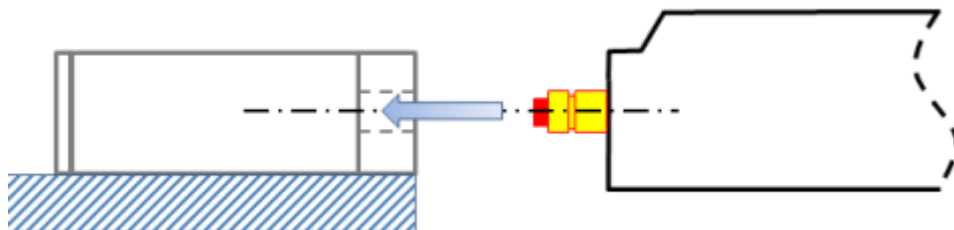

Figure 9: Introducing the shaft

5. Screw in the grub screw until you feel resistance. The torque must **not** exceed 0.3 Nm.  
Fine adjustment: If necessary, correct the position of the locating surface of the actuator in relation to the top edge of the micropositioning stage while or before tightening the grub screw so that they are flush with each other.

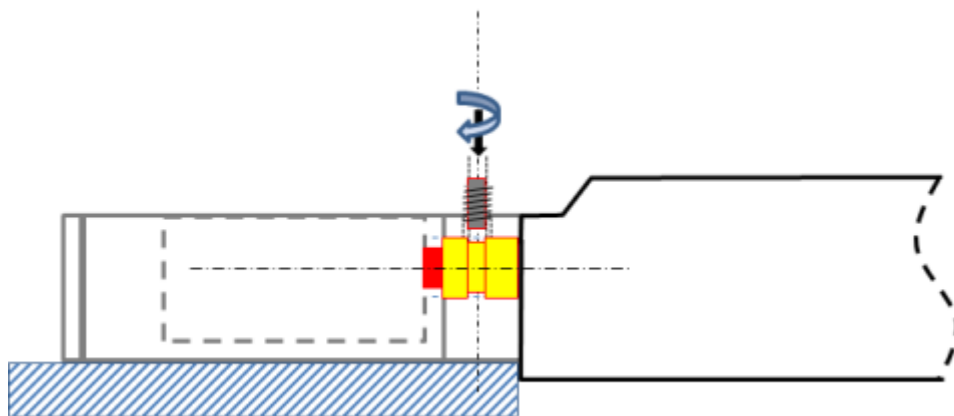

Figure 10: Fastening the actuator

6. Check that the actuator is correctly fitted on the micropositioning stage:
  - Make sure that the installation result corresponds to the conditions in the following figure.

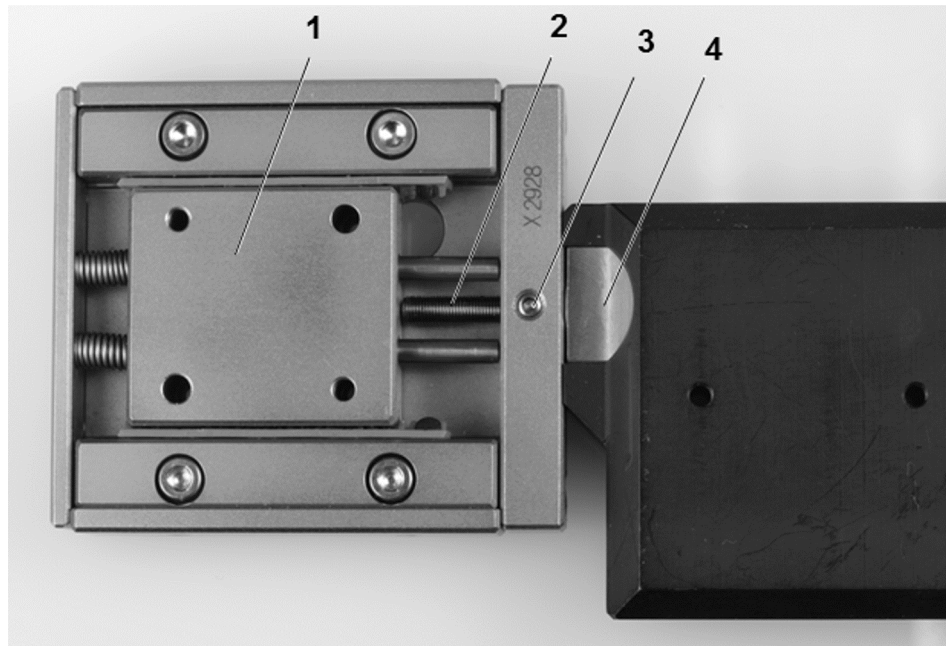

Figure 11: Complete installation: M-232 actuator in a micropositioning stage (here: M-105)

- 1 Moving platform of the micropositioning stage
- 2 Pusher of the M-232 actuator, here completely extended
- 3 Mounting screw: M2 grub screw
- 4 Locating surface of the M-232 actuator, flush with the top edge of the front of the micropositioning stage



## 6 Start-Up

### 6.1 General Notes on Start-Up

#### CAUTION



**Unintentional motion of the linear actuator while connecting it to the motor controller!**

- Do not place any objects in areas where they can get caught by moving parts.
- Keep your fingers at a safe distance from the motion range of the linear actuator.

#### NOTICE



**Damage if a wrong motor controller is connected!**

Connecting a linear actuator to an unsuitable controller can cause damage to the linear actuator or controller.

- Connect a linear actuator with DC motor to a DC motor controller only.
- Connect a linear actuator with stepper motor to a stepper motor controller only.

#### NOTICE



**Damage due to the pusher crashing into the hard stop!**

When the limit switches are deactivated, the motion of the pusher is aborted by the hard stop and the M-232 can be damaged.

- Do **not** deactivate the limit switches in the software.
- Test limit switch operation at low velocities only.

**NOTICE****Damage or major wear to the mechanical system as a result of high acceleration!**

- In the event of a malfunction of the motor controller, stop the motion immediately.
- Ensure that the end of the travel range is approached at low velocity.
- Set your control signal so that the moving part does not stop abruptly or try to continue moving at the end of the travel range.
- Determine the maximum velocity for your application.

**NOTICE****Damage from unsuitable controllers and PC software!**

Unsuitable controllers and PC software can cause damage to the actuator.

- If you use controllers and software from other manufacturers, **before** starting up the actuator, check the technical data to make sure that they are suitable!

**INFORMATION**

The maximum velocity for a linear actuator with a stepper motor should be determined in the application. If the commanded velocity is too high, the stepper motor might stop without the controller detecting this condition.

**INFORMATION**

The handwheel of a linear actuator with stepper motor can be used to manually retract and extend the pusher. Manually triggered changes in the position of the pusher are **not** recognized by the connected controller.

**INFORMATION**

The repeatability of the positioning is only ensured when the same limit switch is always used for the reference move.

- Always start reference moves to the same limit switch.



**INFORMATION**

For models with DC motors:

Unsuitable settings made to the servo-control parameters can impair the performance of the M-232. The consequences of this can be expressed as follows:

- Oscillations
- Imprecise approach of the position
- Settling time is too long
- If the performance of the M-232 is not satisfactory, check the settings for the servo-control parameters of your controller.

**INFORMATION**

Moving the pusher outwards corresponds to the positive direction of motion.

## 6.2 Starting Up the Actuator

In the following, a PC with PC software is used as the peripheral control equipment of the controller.

**Prerequisites**

- ✓ You have read and understood the General Notes on Start-Up (p. 27).
- ✓ You have correctly installed the actuator (p. 15).
- ✓ You have read and understood the user manual of the used controller.
- ✓ You have read and understood the manual of the used PC software.

**Accessories**

- Suitable controller (p. 12) - motor controller card for PC installation or stand-alone device incl. connection cable to PC.
- PC
- PC software for the controller (for PI controllers: included in their scope of delivery)
- If necessary, suitable motor cable from PI:

### Starting up the actuator

1. If you use a motor controller card (e.g. C-843 from PI), make sure that it is properly installed or install it (see the user manual of the motor controller card).
2. If suitable and current PC software for the controller is not on your PC yet, install the PC software (see the user manual of the controller or the software).
3. If you do **not** use a motor controller card, connect the PC with the external controller using a suitable cable.  
For PI products: the cable required for this is included in the scope of delivery.
4. Connect the actuator with the controller:
  - a) Determine the minimum necessary cable length between the actuator and the controller.
  - b) Connect the connector of the connection cable with the Sub-D socket of the controller or a corresponding adapter (according to the determined length, see above) either directly or by interposing an additional motor cable.
  - c) Secure all connections with the integrated screws against accidental disconnection.
  - d) Remove or label resulting danger areas in accordance with the valid legal regulations and directives.
5. Start up the controller (see user manual of the controller).
6. Configure the controller using the PC software for the used actuator (see the user manual of the controller and the PC software):
  - If you use a PI controller: select the entry in the stage database that precisely matches the actuator version used, see the list of available entries (p. 31).
  - If you use a controller from another manufacturer: Enter the parameters in the corresponding PC software that precisely match the actuator version used; see overview of the operating parameters for DC motor controllers (p. 31) or stepper motor controllers (p. 31).
7. Start a few motion cycles for testing purposes (see user manual of the controller).

### 6.2.1 M-232 Entries in the Stage Database of PI

For motor controllers from PI you can select the connected linear actuator from a stage database in the respective PC software. The appropriate operating parameters are thus loaded into the motor controller. You can find a detailed description in the user manual for the motor controller or in the manual for the PC software used.



## 7 Maintenance

### 7.1 General Notes on Maintenance

#### NOTICE



#### Damage due to improper maintenance!

The M-232 can become misaligned as a result of improper maintenance.

- Do not loosen any sealed screws.

### 7.2 Lubricating the M-232

Depending on the operational conditions and the period of use of the linear actuator, the following maintenance measures are required.

#### Spreading lubricant

- If you operate the M-232 continuously on a small travel range (<20% of the entire travel range), perform a maintenance run every 2000 motion cycles across the entire travel range.

#### Lubrication

Under laboratory conditions, the linear actuator needs extra lubrication in exceptional cases only. For continuous industrial use the lubrication intervals must be defined individually.

- Do not lubricate the M-232 without consulting our customer service department (p. 37).
- To lubricate, follow the instructions given in the maintenance manual which you can obtain from our customer service department.

## 7.3 Cleaning the M-232

### Prerequisites

- ✓ You have disconnected the linear actuator from the controller.

### Cleaning the linear actuator

- When necessary, clean the linear actuator surface with a towel lightly dampened with a mild cleanser or disinfectant.
- Do **not** use any organic solvents.

## 8 Troubleshooting

Problem	Possible Causes	Solution
Reduced positioning accuracy	Mounting screw not tight enough or overtightened	➤ Tighten the mounting screw with a maximum torque of 0.3 Nm.
Functional impairment after system modification	Motor controller has been replaced	Motor controller from PI: ➤ Load the parameters from the stage database that correspond to the combination of motor controller and M-232 model (p. 29). Motor controller from a third-party supplier: ➤ Check the operating parameters
The mechanical system does not move	The cable is not connected correctly or is faulty	➤ Check the connector cable.
	Lateral forces are affecting the pusher.	Lateral forces increase the friction on the internal drive components. ➤ Avoid lateral forces on the pusher of the M-231.
The mechanical system does not move, but generates operating noise	Values for the velocity, acceleration and/or load are too high	➤ Reduce the velocity. ➤ Reduce the acceleration. ➤ Reduce the load on the mechanical system.
The mechanical system did not stop in time and ran into the hard stop	<ul style="list-style-type: none"> <li>▪ Velocity is too high (see chapter Limit Switches p. 12)</li> <li>▪ Limit switch is defective</li> <li>▪ Motor controller ignores the limit switch signal</li> </ul>	<ol style="list-style-type: none"> <li>1. Stop the motor.</li> <li>2. Command the mechanical system away from the hard stop.</li> <li>3. Check the settings of the motor controller for the limit switch processing.</li> </ol>

If the problem that occurred with your system is not listed in the table above or it cannot be solved as described, contact our customer service department (p. 37).





## 9 Customer Service

For inquiries and orders, contact your PI sales engineer or send us an e-mail (<mailto:service@pi.de>).

If you have questions concerning your system, have the following information ready:

- Product codes and serial numbers of all products in the system
- Firmware version of the controller (if present)
- Version of the driver or the software (if present)
- Operating system on the PC (if present)

The latest versions of the relevant user manuals for your system are available for download on our website (<http://www.pi.ws>).



## 10 Technical Data

### 10.1 Specifications

#### 10.1.1 Data Table

	M-232.17	Unit	Tolerance
<b>Motion and positioning</b>			
Travel range	17	mm	
Integrated sensor	Rotary encoder		
Sensor resolution	2048	Cts./rev.	
Design resolution	0.007	μm	Typ.
Minimum incremental motion	0.1	μm	Typ.
Backlash	2	μm	Typ.
Unidirectional repeatability	±0.2	μm	Typ.
Velocity	1.5	mm/s	Max.
<b>Mechanical properties</b>			
Drive screw	Leadscrew		
Thread pitch	0.4	mm	
Gear ratio	28.44444:1		
Motor resolution	–	Steps/rev.	
Push/pull force	40	N	Max.
<b>Drive properties</b>			
Motor type	DC gear motor		
Operating voltage	0 to ±12	V	
Motor power	1.78	W	
Limit switches	Hall effect		

	M-232.17	Unit	Tolerance
<b>Miscellaneous</b>	<b>M-232.17</b>		
Operating temperature range	-20 to 65	°C	
Material	Aluminum anodized, chrome steel		
Mass	0.17	kg	±5 %
Cable length	0.5	m	±10 mm
Connector	D-sub 15 (m), incl. encoder driver		
Recommended controllers / drivers	C-863 C-884		

### 10.1.2 Ambient Conditions and Classifications

The following ambient conditions and classifications must be observed for the M-232:

Area of application	For indoor use only
Maximum altitude	2000 m
Relative humidity	Highest relative humidity 80% for temperatures up to 31°C Decreasing linearly to 50% relative humidity at 40°C
Storage temperature	0°C to 80°C
Transport temperature	0°C to 80°C
Supply fluctuations	Not more than ±10% of the nominal voltage
Degree of pollution	2
Degree of protection according to IEC 60529	IP40

### 10.1.3 Limit Switch Specifications

Type	Magnetic (Hall-effect) sensor
Supply voltage	+5 V/ground
Signal output	TTL level
Signal logic	<p>The signal level changes when passing the limit switch. The signal logic depends on the model type:</p> <ul style="list-style-type: none"><li>▪ Models with DC motor: <b>active high</b>. That means:<ul style="list-style-type: none"><li>– Normal motor operation: low (0 V)</li><li>– Limit switch reached: high (+5 V)</li></ul></li><li>▪ Models with stepper motor: <b>active low</b>. That means:<ul style="list-style-type: none"><li>– Normal motor operation: high (+5 V)</li><li>– Limit switch reached: low (0 V)</li></ul></li></ul>

## 10.2 Dimensions

Dimensions in mm. Note that the decimal places are separated by a comma in the drawings.

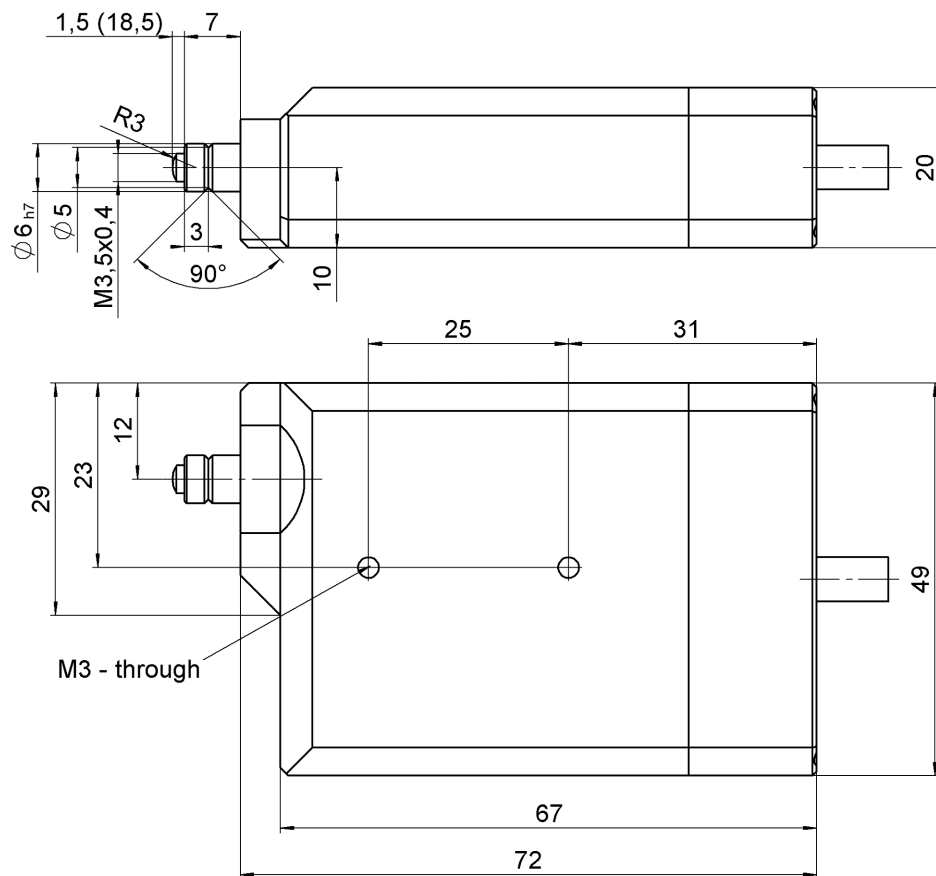

Figure 12: M-232.17 and M-232.17S linear actuator, dimensions in mm

## 10.3 Pin Assignment

### 10.3.1 Model with DC Gear Motor

Connector: 15-pin sub-D (m)

Pin No.	Function
1	Internal
9	Input: Motor (-)
2	Input: Motor (+)
10	Internal
3	Internal
11	Internal
4	Input: +5 V supply from controller
12	Output: Limit switch signal, negative side
5	Output: Limit switch signal, positive side
13	Internal
6	GND (limit switch and logic)
14	Output: Encoder A (+)
7	Output: Encoder A (-)
15	Output: Encoder B (+)
8	Output: Encoder B (-)

### 10.3.2 Model with Stepper Motor

#### Connector: 15-pin sub-D (m)

Pin No.	Function
1	Input: Phase 1a
9	Input: Phase 1b
2	Input: Phase 2a
10	Input: Phase 2b
3	Not connected
11	Not connected
4	Not connected
12	Not connected
5	Not connected
13	Not connected
6	Input: +5 V supply from controller
14	Output: Limit switch signal, positive side
7	GND
15	Internal
8	Output: Limit switch signal, negative side



## 11 Old Equipment Disposal

Since 13 August 2005, in accordance with the EU directive 2002/96/EC (WEEE), electrical and electronic equipment can no longer be disposed of in the member states of the EU with other wastes.

When disposing of your old equipment, observe the international, national and local rules and regulations.

To meet the manufacturer's product responsibility with regard to this product, Physik Instrumente (PI) GmbH & Co. KG ensures environmentally correct disposal of old PI equipment that was first put into circulation after 13 August 2005, free of charge.

If you have old PI equipment, you can send it postage-free to the following address:

Physik Instrumente (PI) GmbH & Co. KG  
Auf der Römerstr. 1  
D-76228 Karlsruhe, Germany





## 12 EC Declaration of Conformity

PI

---

**Declaration of Conformity**  
according to DIN EN ISO/IEC 17050-1

---

**Manufacturer:** Physik Instrumente (PI)  
GmbH & Co. KG

**Manufacturer's Address:** Auf der Roemerstraße 1  
D-76228 Karlsruhe,  
Germany

CE

**The manufacturer hereby declares that the product**

**Product Name:** Precision Linear Actuator

**Model Numbers:** M-232

**Product Options:** all

complies with all relevant provisions of the **Machinery Directive (2006/42/EC)**.  
Furthermore, it complies with all provisions of the **Low Voltage Directive (2006/95/EC)** and the **EMC Directive (2004/108/EC)**.

**The applied standards certifying the conformity are listed below.**

**Safety of Machinery:** EN 12100-1, EN-12100-2

**Safety (Low Voltage Directive):** EN 61010-1

**Electromagnetic Emission:** EN 61000-6-3, EN 55011

**Electromagnetic Immunity:** EN 61000-6-1

The person authorized to compile the technical file is: Wolfgang Schobel  
Address: see manufacturer's address

April 20, 2011  
Karlsruhe, Germany

  
 Dr. Karl Spanner  
 President

Physik Instrumente (PI) GmbH & Co. KG, Auf der Roemerstraße 1, 76228 Karlsruhe, Germany  
Phone +49 721 4846-0, Fax +49 721 4846-1019 E-mail info@pi.ws, www.pi.ws

PIEZO NANO POSITIONING  
