

P-810 · P-830

Small-Load Open-Loop Piezo Translators (LVPZT)

>> Click <http://www.pi.ws/fwd/Piezo-Actuator> for the Latest Specs on these Products



- Travel Range to 60 μm
- Pushing Forces to 1000 N
- Pulling Forces to 5 N
- Sub-ms Response
- Sub-nm Resolution

P-810 and P-830 series translators are high-resolution linear actuators for static and dynamic applications. They provide sub-millisecond response and sub-nanometer resolution.

Design

These actuators consist of a highly reliable monolithic multilayer piezoceramic stack protected by a stainless steel case.

PI offers a variety of preloaded translators for applications involving higher tensile loads (see the "Selection Guide" on p. 1-8).

Mounting

Attachment is via the ferromagnetic end surfaces, with epoxy or magnets. For mounting information and decoupling pulling, bending and shear forces—especially important with non-preloaded actuators—see the mounting guidelines, page 1-48.

Accessories

Extension cable with connectors: see page 6-55 in the "Piezo Drivers & Nanopositioning Controllers" section.

Notes

High-resolution amplifiers and servo-control electronics, both digital and analog, are described in the "Piezo Drivers & Nanopositioning Controllers" section, page 6-8 *ff.*

Application Examples

- Static and dynamic precision positioning
- Fiber alignment
- Laser tuning
- Patch clamp
- Nanotechnology

For more examples, see page 1-5

Piezo Actuators

Nanopositioning & Scanning Systems

Active Optics / Steering Mirrors

Tutorial: Piezo-electrics in Positioning

Capacitive Position Sensors

Piezo Drivers & Nanopositioning Controllers

Hexapods / Micropositioning

Photonics Alignment Solutions

Motion Controllers

Ceramic Linear Motors & Stages

Index

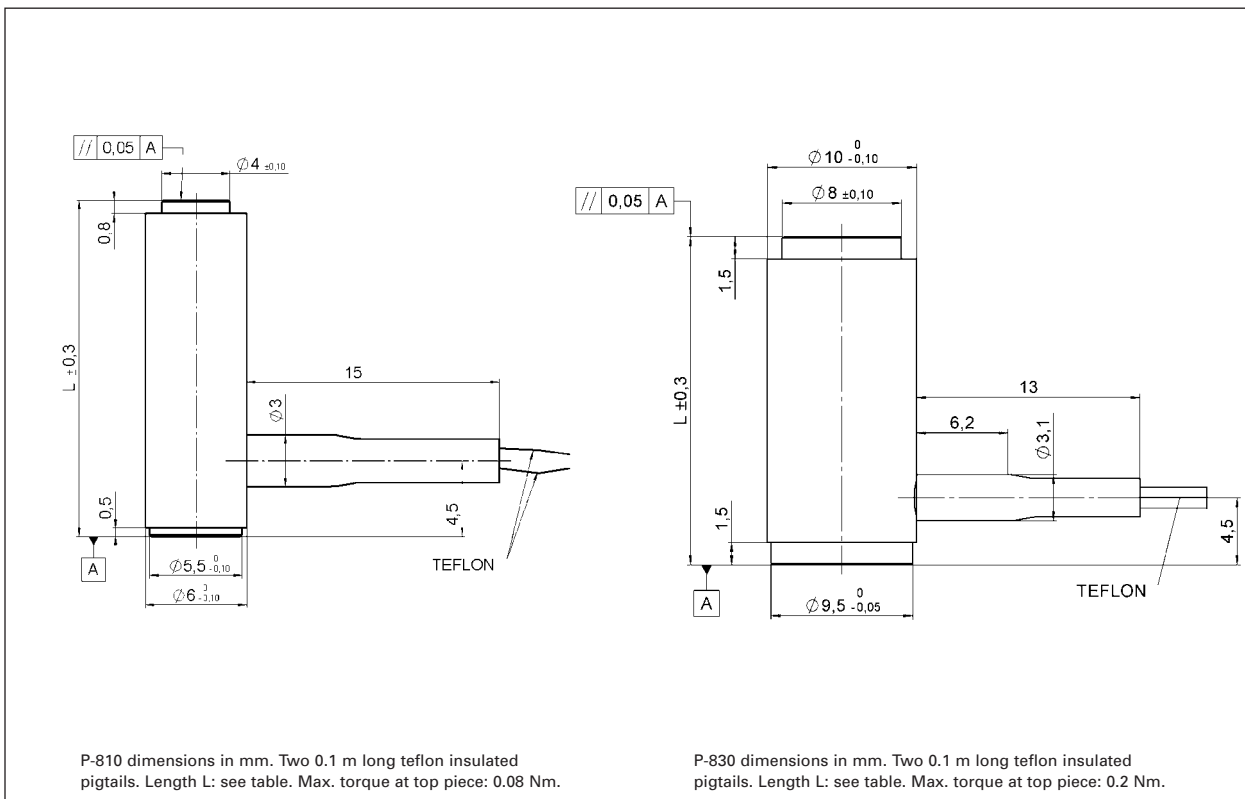

Technical Data and Product Order Numbers

Order number	Travel range for 0 to 100 V [μm] ±20%	Resolution* [nm]	** Static large-signal stiffness [N/μm] ±20%	Push- / pull force capacity [N]	Electrical capacitance [μF] ±20%	Dynamic operating current coefficient [μA / (Hz x μm)]	Resonant frequency (unloaded) [kHz] ±20%	Weight [g] ±5%	Length L [mm] ±0,3
P-810.10	15	0.15	14	50 / 1	0.3	3	22	4	20
P-810.20	30	0.3	7	50 / 1	0.7	3	15	6	38
P-810.30	45	0.45	4	50 / 1	1	3	12	8	56
P-830.10	15	0.15	57	1000 / 5	1.5	12.5	23	10	22
P-830.20	30	0.3	27	1000 / 5	3	12.5	14	16	40
P-830.30	45	0.45	19	1000 / 5	4.5	12.5	10	21	58
P-830.40	60	0.6	15	1000 / 5	6	12.5	8.5	27	76
Notes see page 1-46	A2	C1	D1	D3	F1	F2	G2	K	

* Resolution of piezo actuators is not limited by friction or stiction. Value given is noise equivalent motion with E-503 amplifier.

** Dynamic small-signal stiffness ~30% higher. Operating temperature range: -20 to 120 °C. Case: non-magnetic steel; end pieces: stainless steel. Recommended preload for dynamic operation: 10 - 20 MPa.