

P-239 · P-244 · P-245

Preloaded Open- & Closed-Loop Translators (HVPZT)

>> Click <http://www.pi.ws/fwd/Piezo-Actuator> for the Latest Specs on these Products



P-239 piezo actuators (battery for size comparison)

- Travel Range to 180 μm
- Pushing Forces to 4500 N
- Pulling Forces to 500 N
- Sub-ms Response
- Sub-nm Resolution
- Options: Vacuum, High- and Low-Temperature

P-244 / P-245 and P-239 series translators are high-resolution linear actuators for static and dynamic applications. They provide sub-millisecond response and sub-nanometer resolution.

Application Examples

- Static and dynamic precision positioning
- Optics
- Metrology / interferometry
- Active structures (adaptronics)
- Precision engineering / micromechanisms
- Adaptive mechanics
- Active vibration control
- Switching applications
- Laser tuning
- Force generation / materials testing
- Nanotechnology

For more examples, see page 1-5

Design

These actuators consist of a friction-free, preloaded piezo-ceramic stack protected by a non-magnetic, stainless steel case. The preload makes these actuators ideal for dynamic applications (e.g. precision

machining, active damping, etc.) and push-pull applications. The ceramic layers in the P-239 and P-245 models are double in number and thinner than those in the P-244, thus providing larger travel ranges. For maximum lifetime, voltages in excess of -750 V should be applied only for short durations.

Mounting

Mounting is at the foot, although with push/pull forces of less than 5 N, the actuator can be held by clamping the case. The optional ball tip (P-244.95 or P-239.95) is intended to decouple torque and off-center forces from the translator. For more examples, see page 1-5.

High Accuracy in Closed-Loop Operation

The standard models are designed for open-loop operation. The factory-installed P-177.10 option of integrated high-resolution SGS-position sensors is recommended for high accuracy through position

servo-control (for more information, see "Tutorial: Piezoelectrics in Positioning," p. 4-31 ff.).

Options #:

P-177.10
SGS Position Sensors, p. 1-44 (not with P-239.00 / P-239.10)

P-702.10
High-temperature option, p. 1-44

P-702.20
Low-temperature option, p. 1-44

P-703.20
High-vacuum option, p. 1-44.

P-239.95
Ball tip for P-239, p. 1-44

P-244.95
Ball tip for P-244/P-245, p. 1-44

To order an actuator with options, change the last digit of the actuator order number to "7" (e.g. P-239.00 to P-239.07) and then list the desired options separately.

Technical Data and Product Order Numbers

Order number	Open-loop travel @ 0 V to -1000 V [μm] $\pm 20\%$	Closed-loop travel [μm]	Integrated position sensor*	Resolution closed-loop / open-loop [nm]**	Large-Signal stiffness [$\text{N}/\mu\text{m}$] $\pm 20\%$ ***	Push/pull force capacity [N]
P-244.10	10	10*	*SGS	0.2* / 0.1	90	2000 / 300
P-244.20	20	20*	*SGS	0.4* / 0.2	45	2000 / 300
P-244.30	40	40*	*SGS	0.8* / 0.4	22	2000 / 300
P-244.40	60	60*	*SGS	1.2* / 0.6	15	2000 / 300
P-245.20	20	20*	*SGS	0.4* / 0.2	80	2000 / 300
P-245.30	40	40*	*SGS	0.8* / 0.4	40	2000 / 300
P-245.50	80	80*	*SGS	1.6* / 0.8	20	2000 / 300
P-245.70	120	120*	*SGS	2.4* / 1.2	15	2000 / 300
P-239.00	5	-	-	- / 0.05	850	4500 / 500
P-239.10	10	-	-	- / 0.1	460	4500 / 500
P-239.20	20	20*	*SGS	0.4* / 0.2	250	4500 / 500
P-239.30	40	40*	*SGS	0.8* / 0.4	140	4500 / 500
P-239.40	60	60*	*SGS	1.2* / 0.6	95	4500 / 500
P-239.60	100	100*	*SGS	2* / 1	55	4500 / 500
P-239.80	140	140*	*SGS	2.8* / 1.4	40	4500 / 500
P-239.90	180	180*	*SGS	3.6* / 1.8	35	4500 / 500
Notes see page 1-46	A4	A6	B	C2	D1	D3

Accessories

Extension cables with connectors: see page 6-56 in the “Piezo Drivers & Nanopositioning Controllers” section.

Notes

High-resolution amplifiers and servo-control electronics, both digital and analog, are described in the “Piezo Drivers & Nanopositioning Controllers” section, page 6-8 ff. For actuators without cases, see pages 1-18. 1-20, 1-22.

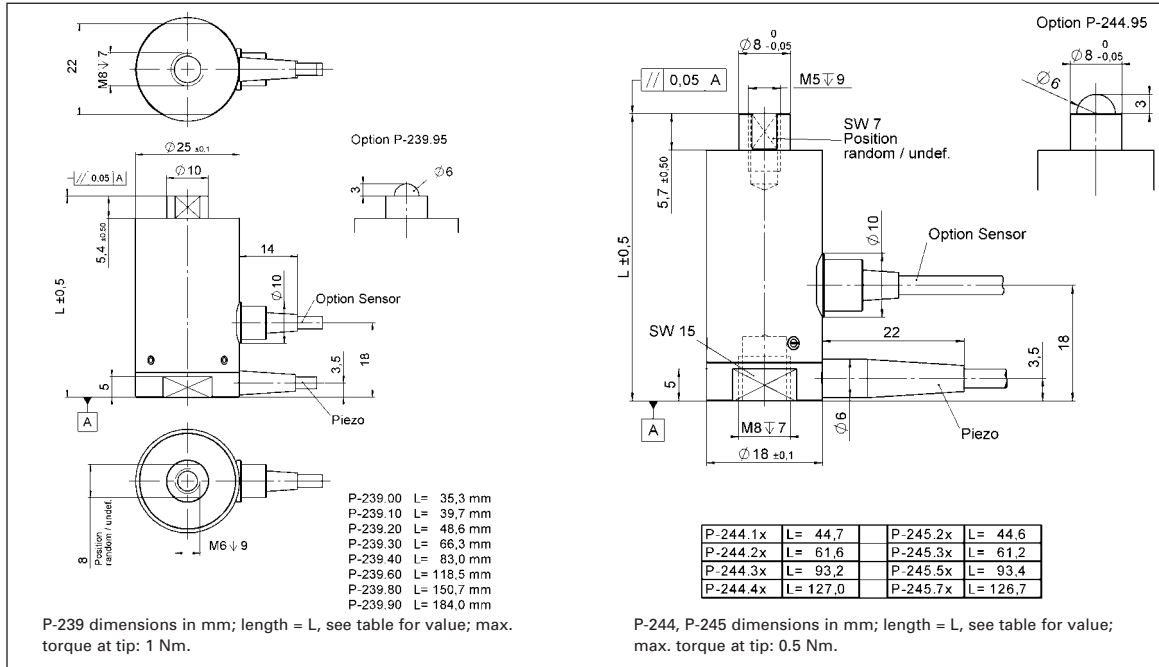

Piezo Actuators

Nanopositioning & Scanning Systems

Active Optics / Steering Mirrors

Tutorial: Piezo-electrics in Positioning

Capacitive Position Sensors

Piezo Drivers & Nanopositioning Controllers

Hexapods / Micropositioning

Photonics Alignment Solutions

Motion Controllers

Ceramic Linear Motors & Stages

Index

Max. operating voltage [V]	Electrical capacitance [nF] ±20%	Dynamic operating current coefficient [µA/(Hz x µm)]	Resonant frequency (unloaded) [kHz] ±20%	Weight without cable [g] ±5%	Recommended amplifier / controller (codes explained p. 1-3)
-1500	25	3	14	59	B, I, J
-1500	47	3	8	72	B, I, J
-1500	89	3	5	102	B, I, J
-1500	133	3	3.5	136	B, I, J
-1000	95	6	13	59	B, I, J
-1000	180	6	8	72	B, I, J
-1000	340	6	5	102	B, I, J
-1000	500	6	3.5	136	B, I, J
-1000	70	17.5	12	85	B, J
-1000	120	17.5	10	94	B, J
-1000	245	17.5	8	112	B, I, J
-1000	460	17.5	6.5	148	B, I, J
-1000	660	17.5	5.6	184	B, I, J
-1000	1150	17.5	4	256	B, I, J
-1000	1550	17.5	3	328	B, I, J
-1000	2100	17.5	2	400	B, I, J
A7	F1	F2	G2	K	

* Requires SGS sensor option, P-177.10. SGS versions can attain closed-loop linearity up to 0.2% and are shipped with performance reports.

Sensor connection: LEMO FFA.0S.304; 1 m coaxial cable with PUR insulation.

** The resolution of piezo actuators is not limited by stiction or friction. Value given is noise equivalent motion with E-507 amplifier.

*** Dynamic small-signal stiffness is ~50% higher.

Voltage connection: LEMO FFA.0A.250, 1 m coaxial cable, RG 174, PVC-insulation.

Temperature range: -40 to 80 °C.

Case / end pieces: non magnetic steel / stainless steel.