

# PT120 - PT140

## Piezoceramic Tubes (HVPZT)

>> Click <http://www.pi.ws/fwd/Piezo-Actuator> for the Latest Specs on these Products



Selection of PT piezoceramic tubes.

- Standard & Custom Sizes
- For OEM Applications
- XYZ-Positioning
- Sub-Nanometer Resolution
- Large Diameters to 80 mm
- Wall Thickness as Small as 0.3 mm

PT-series piezoceramic tubes are used in a wide range of applications from microdispensing to scanning microscopy. These monolithic components contract laterally (radially) and longitudinally when a voltage is applied between

their inner and outer electrodes. Multi-electrode tubes are available to provide XYZ motion for use in manipulation and scanning microscopy applications. PI also provides ultra-high-linearity, closed-loop scanning stages for SPM and nanomanipulation.

### Application Examples

- Micropositioning
- Scanning microscopy (STM, AFM, etc.)
- Fiber stretching / modulation of optical path length
- Micro pumps / ink-jet printing
- Micromanipulators
- Ultrasonic and sonar applications

### Precision and Flexibility: PI Ceramic's Strength

PT piezo tubes are manufactured to the tightest tolerances. We can provide tubes with diameters as small as 0.8 mm and tolerances as tight as 0.025 mm.

All manufacturing processes at PI Ceramic are set up for flexibility. Should our standard actuators not fit your application, let us provide you with a custom design. Our engineers

will work with you to find the optimum solution at a very attractive price, even for small quantities. Some of our custom capabilities are listed below:

- Custom Materials
- Custom Voltage Ranges
- Custom Geometries
- Custom Displacement
- Extra-Tight Tolerances
- Applied Sensors
- Special High / Low Temperature Versions
- Ultra-High-Vacuum Versions

### Short Leadtime for Standard & Custom Designs

Because all piezoelectric materials used in PT tube actuators are manufactured at PI Ceramic, leadtimes are short and quality is outstanding. All standard and custom actuators are delivered with performance test sheets.

### Amplifiers, Drivers & Controllers

PI offers a wide range of control electronics for piezo actuators from low power drivers to multi-channel, closed-loop, digital controllers.

### Design

Dimensions: max. L: 50 mm  
max. OD: 80 mm  
min. wall thickness: 0.30 mm

**Electrodes:** fired silver-plated inside and outside as standard; thin film electrodes (e.g. copper-nickel or gold) as outer electrodes optional

**Options:** single or double wrapped, circumferential bands or quartered outer electrodes

**Polarization:** inner electrode positive potential

Tube actuators are not designed to withstand large forces (see PICA-Thru actuators), but their high resonant frequencies make them especially suitable for dynamic operation with light loads.



XY scanning tubes with quartered outer electrodes; see table for specifications.

### Useful Equations

Axial contraction and radial displacement of piezo tube actuators can be estimated by the following equations:

#### (Equation 1)

$$\Delta L \approx d_{31} \cdot L \cdot \frac{U}{d}$$

where:

$d_{31}$  = strain coefficient (displacement normal to polarization direction) [m/V]

$L$  = length of the ceramic tube [m]

$U$  = operating voltage [V]

$d$  = wall thickness [m]

#### (Equation 2)

$$\Delta d \approx d_{33} \cdot U$$

where:

$\Delta d$  = change in wall thickness [m]

$d_{33}$  = strain coefficient (field and displacement in polarization direction) [m/V]

$U$  = operating voltage [V]

Typical values for  $d_{31}$  and  $d_{33}$  are -200 pm/V and 500 pm/V, respectively.

The radial contraction is the superposition of the increase in wall thickness and the tangen-

tial contraction; it can be estimated by the following equation:

#### (Equation 3)

$$\frac{\Delta r}{r} \approx d_{31} \frac{U}{d}$$

where:

$r$  = tube radius

$d_{31}$  = strain coefficient (displacement normal to polarization direction) [m/V]

$U$  = operating voltage [V]

$d$  = wall thickness [m]

The quartered electrodes option makes XY scanning possible. These scanner tubes, which flex in X and Y, are widely used in scanning-probe microscopes. The scan range of these components is estimated by:

#### (Equation 4)

$$\Delta x \approx \frac{2\sqrt{2} \cdot d_{31} \cdot L^2 \cdot U}{\pi \cdot ID \cdot d}$$

where:

$\Delta x$  = scan range in X and Y (for symmetrical electrodes) [m]

$d_{31}$  = strain coefficient (displacement normal to polarization direction) [m/V]

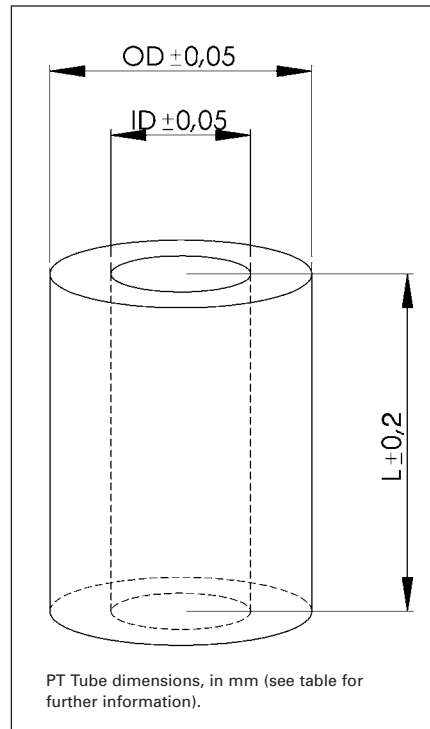

$U$  = symmetric operating voltage [V]

$L$  = length [m]

$ID$  = inner diameter [m]

$d$  = wall thickness [m]

### Technical Data / Product Order Numbers

Order number	Dimensions L x OD x ID**	Max. operating voltage [V]	Electrical capacitance [nF ±20%]	Axial contraction $\mu\text{m}$ @ max. V	Radial contraction $\mu\text{m}$ @ max. V	XY deflection [ $\mu\text{m}$ ]
PT120.00	20 x 2.2 x 1.0	500	3	4		n/a
PT130.00	30 x 3.2 x 2.2	500	10	8	0.5	n/a
PT130.90	30 x 3.2 x 2.2	500	12	8	0.6	n/a
PT130.94*	30 x 3.2 x 2.2	±200	4 x 2.4	8	0.6	±6
PT130.10	30 x 6.35 x 5.35	500	18	6	1.0	n/a
PT130.14*	30 x 6.35 x 5.35	±200	4 x 3.8	6	1.0	±8
PT130.20	30 x 10.0 x 9.0	500	36	8	4	n/a
PT130.24*	30 x 10.0 x 9.0	±200	4 x 8.5	8	4	±14
PT130.30	30 x 10.0 x 8.0	1000	18	8	3	n/a
PT130.40	30 x 20.0 x 18.0	1000	35	8	5	n/a
PT140.70	40 x 40.0 x 38.0	1000	70	15	10	n/a

All models available with 40 mm length, except PT120.00

\* Quartered electrodes for XY deflection

\*\* OD, ID ±0.05 mm all models except PT120 / PT 130.00 (±0.1 mm)

### Piezo Actuators

Nanopositioning & Scanning Systems

Active Optics / Steering Mirrors

Tutorial: Piezo-electrics in Positioning

Capacitive Position Sensors

Piezo Drivers & Nanopositioning Controllers

Hexapods / Micropositioning

Photonics Alignment Solutions

Motion Controllers

Ceramic Linear Motors & Stages

Index