

**PL112-  
PL140**

## PICMA™ Multilayer Bender Actuators

>> Click <http://www.pi.ws/fwd/Piezo-Actuator> for the Latest Specs on these Products

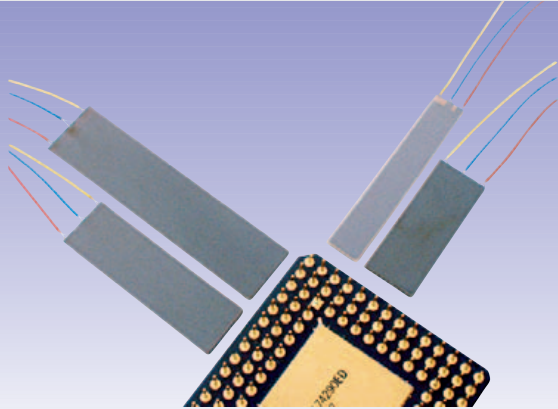

Bender actuators with optional wire leads (order number extension .x1); microprocessor for size comparison.

- For OEM Applications
- Ceramic Insulation
- Positioning Range up to 2 mm
- Fast Response (< 10 msec)
- Nanometer-Range Resolution
- Low Operating Voltage
- Vacuum-Compatible Versions
- Available with Integrated Position Sensor
- Special OEM and Bench-Top Amplifiers/Drivers Available

PICMA™-series multilayer bender piezo actuators provide a deflection of up to 2 mm, forces up to 2 N (200 grams) and response times in the millisecond range. These multilayer piezoelectric components are manufactured from ceramic layers of only about 25 µm thickness. They feature internal silver-palladium electrodes and ceramic insulation applied in a co-firing process. The bender have two outer active areas and one central electrode network dividing the actuator in two segments of

equal capacitance, similar to a classical parallel bimorph.

### Advantages

PICMA™ Bender piezo actuators offer several advantages over classic bimorph components manufactured by gluing together two ceramic plates (0.1 to 1 mm thick): faster response time and higher stiffness. The main advantage, however, is the drastically reduced (by a factor of 3 to 10) operating voltage of 60 V only. The reduced voltage allows smaller drive electronics and new applications, such as in medical equipment. Additionally these devices offer an improved humidity resistance due to the 100% ceramic insulation.

### Long Lifetime and High Performance—Ideal for Dynamic Operation

PICMA™ Bender actuators are superior to conventional actuators in high-endurance situations. They show substantially longer lifetimes both in static and dynamic operation, even in harsh environments. The monolithic, ceramic-insulated design makes polymer-film insulation unnecessary. Diffusion of water molecules into the insulation layer, the major cause of dielectric breakdown, is greatly reduced by the use of cofired, outer ceramic insulation.

The high Curie temperature of 320 °C gives PICMA™ actuators a usable temperature range extending up to 150 °C, well above the 80 °C limit of conventional multilayer actuators. At the low end, operation down to a few kelvin is possible (with some reduction in performance specifications).

### Optimum UHV Compatibility—Minimal Outgassing

The lack of polymer insulation and the high Curie temperature make for optimal ultra-high-vacuum compatibility (no measurable outgassing / high bakeout temperatures, up to 150 °C).

### Amplifiers, Drivers & Controllers

PI offers a wide range of standard amplifiers and controllers for piezo actuators (see page 28 and [www.pi.ws](http://www.pi.ws)). The E-650.00 and E-650.OE drivers were specifically designed to operate PICMA™ Bender actuators. For closed-loop positioning applications, a variety of analog and digital controllers are available. Of course, PI also designs custom amplifiers and controllers.

### Application Examples

- Wire bonding
- Pneumatic valves
- Fiber optic switches
- Beam deflection
- Micropositioning
- Acceleration sensors

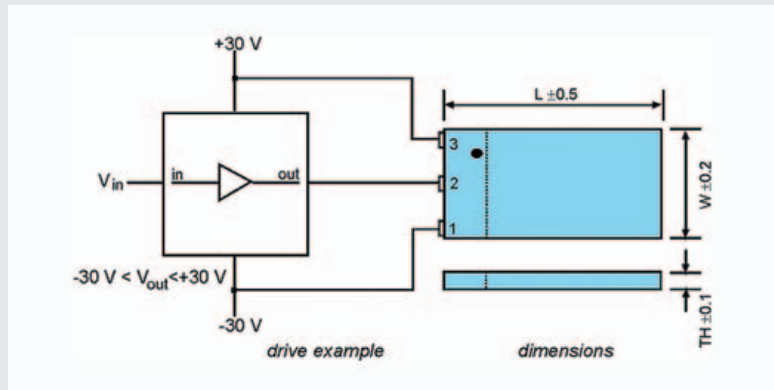
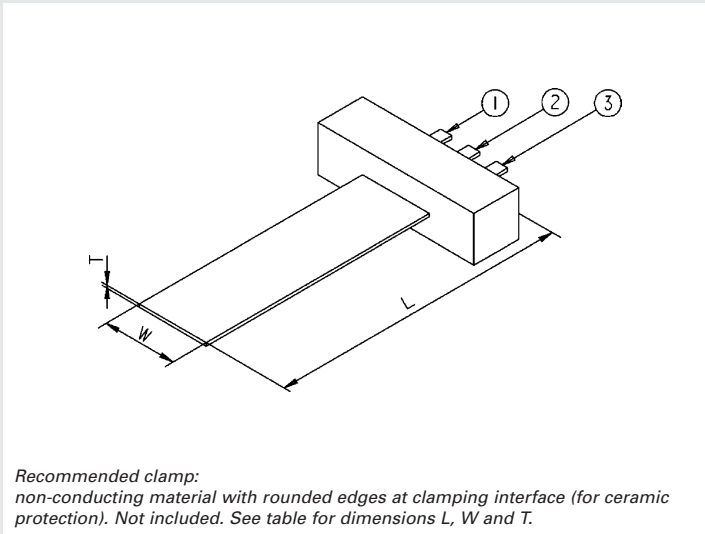
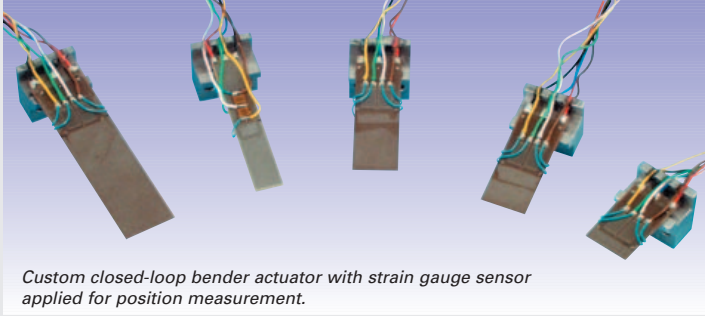

Full differential voltage control.  
Pin assignment: 1 -30 V [or GND]  
2 -30 V to +30 V [or 0 to 60 V]  
3 +30 V [or +60 V]

## Technical Data / Ordering Numbers

Ordering Number*	Operating Voltage [V]	Nominal displacement [ $\mu\text{m} \pm 20\%$ ]	Free length [mm]	Dimensions L x W x T [mm]	Blocking Force [N]	El. capacitance [ $\mu\text{F} \pm 20\%$ ]	Unloaded Resonant Frequency [Hz]
PL112.10**	0 - 60	$\pm 80$	12	17.8 x 9.6 x 0.65	2.0	2 x 1.1	> 1000
PL122.10	0 - 60	$\pm 250$	22	25.0 x 9.6 x 0.65	1.1	2 x 2.4	660
PL127.10	0 - 60	$\pm 450$	27	31.0 x 9.6 x 0.65	1.0	2 x 3.4	380
PL128.10**	0 - 60	$\pm 450$	28	35.5 x 6.3 x 0.75	0.5	2 x 1.2	360
PL140.10	0 - 60	$\pm 1000$	40	45.0 x 11.0 x 0.6	0.5	2 x 4.0	160

\* For optional 100 mm wire leads change order number extension to .x1 (e.g. PL 112.11).

All parameters depend on actual clamping conditions and applied load.  
Operating Temperature: -20 °C to +85 °C (\*\* max. 150 °C)  
Low temperature option available  
Closed-loop option on request (strain-gauge-sensor)

Other specifications on request.  
Specifications subject to change without notice.  
Capacitance measured at 1 V<sub>pp</sub>, 1 kHz