

M-060 · M-061 · M-062

Series Rotation Stages with Worm Gear Drive

>> Click <http://www.pi.ws/fwd/Micropositioning> for the Latest Specs on these Products



M-062.PD, M-061.PD and M-060.PD
from front to rear

- Continuous Rotation
- Ultra-High Resolution
- Velocity up to 90 deg/sec.
- Preloaded Worm Drive for Zero Backlash
- ActiveDrive™ DC-Motor, Stepper-Motor and Manual Versions
- Compatible with Leading Industrial Motion Controllers
- Direction-Sensing Origin Switch

M-06x series rotation stages are equipped with ultra-precise, ultra-low-friction, spring-preloaded worm gear drives allowing unlimited rotation in either direction. Models M-060 feature a 60 mm diameter turntable, models M-061, a 100 mm table and models M-062, a

120 mm table. One manual drive and three motor drives (four with M-062 models) are available:

M-06x.PD ActiveDrive™

This version features a direct-coupled motor/encoder. For superior dynamic performance, we integrated our unsurpassed ActiveDrive™ system. This unique design features a high-efficiency, PWM servo-amplifier mounted side-by-side with the motor. It provides several decisive advantages:

- Increased efficiency, by eliminating power losses between the amplifier and motor

- Reduced cost of ownership and improved reliability, because no external driver is required
- Elimination of PWM amplifier noise radiation, because the amplifier and motor are mounted together in the same electrically shielded case

M-06x.DG DC Motor/Gearhead Drive

The M-06x.DG are equipped with 3-watt DC motors with zero-backlash gearhead and shaft-mounted encoders (2048 counts/rev.). The gear ratio of 29.6:1, provides higher resolution than the direct drive motors.

M-60x.2S Stepper Motor Drive

The M-060x.2S are equipped with direct-drive, micro-stepped, 2-phase, stepper motors (20,000 counts/rev. with C-600 controller), providing ultra-smooth, vibration-free positioning.

Non-Contact Origin Switch

Motorized models are equipped with an integrated Hall-effect origin switch. For ease of operation and setup, all models come with a scale ring on the outer edge of the turntable, graduated in 2-degree increments. The manual versions also feature a drive-shaft-mounted indicator with 0.1-degree graduations.

Optional Limit Switches

To protect your equipment and increase versatility in automation applications, the rotary stage can optionally be equipped with Hall-effect limit switches. Travel can be limited to a range between 0° and 268° (± 2°).

Ordering Information

M-060.PD
Rotation Stage, ø 60 mm, >360°, ActiveDrive™ DC-Motor (Includes Power Supply)

M-060.DG
Rotation Stage, ø 60 mm, >360°, Closed-Loop DC-Motor / Gearhead Drive

M-060.2S
Rotation Stage, ø 60 mm, >360°, 2-Phase Stepper-Motor Drive

M-060.M0
Rotation Stage, ø 60 mm, >360°, Manual Drive

M-061.PD
Rotation Stage, ø 100 mm, >360°, ActiveDrive™ DC-Motor (Includes Power Supply)

M-061.DG
Rotation Stage, ø 100 mm, >360°, Closed-Loop DC-Motor / Gearhead Drive

M-061.2S
Rotation Stage, ø 100 mm, >360°, 2-Phase Stepper-Motor Drive

M-061.M0
Rotation Stage, ø 100 mm, >360°, Manual Drive

M-062.PD
Rotation Stage, ø 120 mm, >360°, ActiveDrive™ DC-Motor (Includes Power Supply)

M-062.DG
Rotation Stage, ø 120 mm, >360°, Closed-Loop DC-Motor / Gearhead Drive

M-062.2S
Rotation Stage, ø 120 mm, >360°, 2-Phase Stepper-Motor Drive

M-062.M0
Rotation Stage, ø 120 mm, >360°, Manual Drive

Ask about custom designs!

Application Examples

- Metrology
- Quality control
- Photonics packaging
- Semiconductor test equipment
- Disk drive test assemblies
- R&D

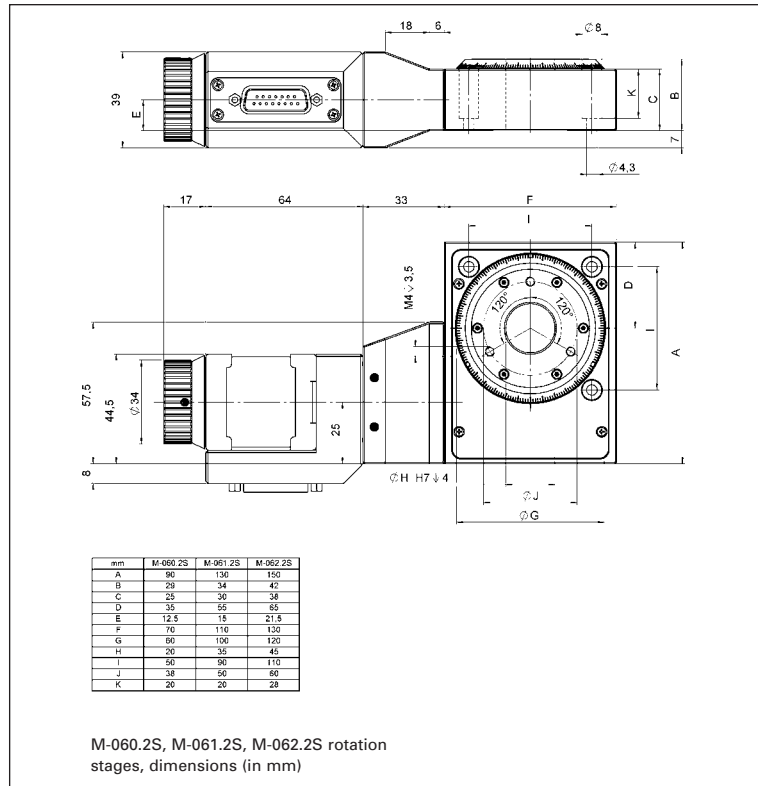
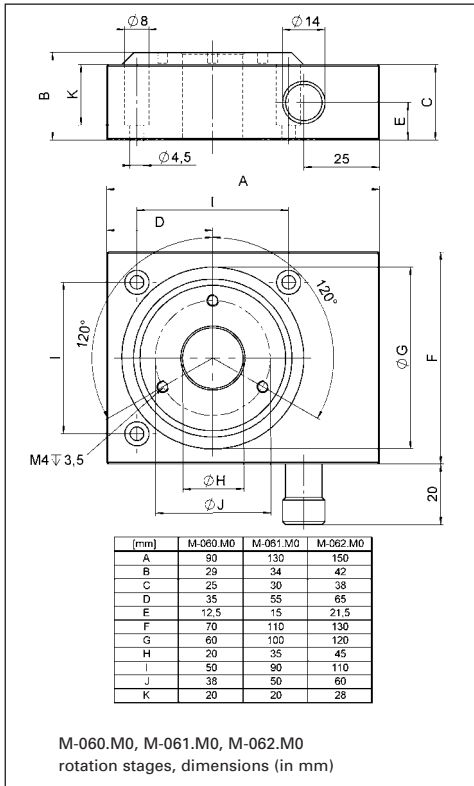

- Piezo Actuators
- Nanopositioning & Scanning Systems
- Active Optics / Steering Mirrors
- Tutorial: Piezo-electrics in Positioning
- Capacitive Position Sensors
- Piezo Drivers & Nanopositioning Controllers
- Hexapods / Micropositioning**
- Photonics Alignment Solutions
- Motion Controllers
- Ceramic Linear Motors & Stages
- Index

Technical Data

Models	M-060.M0	M-060.PD	M-060.DG	M-060.2S	M-061.M0	M-061.PD	M-061.DG	M-061.2S	M-062.M0	M-062.PD	M-062.DG	M-062.2S	Units#
Rotation range	>360	>360	>360	>360	>360	>360	>360	>360	>360	>360	>360	>360	°
Design resolution	-	32 (0.0018)	2.1 (0.00012)	6.3 (0.00036)	-	17.5 (0.001)	1.2 (6.9 x 10 ⁻⁵)	3.5 (0.0002)	-	15 (0.0008)	0.96 (5.5 x 10 ⁻⁵)	2.9 (0.00016)	µrad (°)
Min. incremental motion	-	32	6.3	19	-	17.5	6	10.5	-	15	5	9	µrad
Unidirectional repeatability	-	50	50	50	-	50	50	50	-	60	60	60	µrad
Backlash	-	200	200	200	-	200	200	200	-	240	240	240	µrad
Max. velocity	-	90	16	36	-	90	9	20	-	90	7.3	16	°/s
Maximum axial force	±500	±500	±500	±500	±550	±550	±550	±550	±650	±650	±650	±650	N
Maximum torque (θ _x , θ _y)	±6	±6	±6	±6	±6	±6	±6	±6	±7	±7	±7	±7	Nm
Maximum torque CW, CCW**	4	4	4	4	6	6	6	6	8	8	8	8	Nm
Encoder resolution	-	4,000	2,000	-	-	4,000	2,000	-	-	4,000	2,000	-	Imp./rev.
Motor resolution	-	-	-	20,000 *	-	-	-	20,000 *	-	-	-	20,000 *	
Gear ratio	-	-	(28/12) ⁴ : 1 ≈ 29.6:1	-	-	-	(28/12) ⁴ : 1 ≈ 29.6:1	-	-	-	(28/12) ⁴ : 1 ≈ 29.6:1	-	
Worm gear ratio	50:1	50:1	50:1	50:1	90:1	90:1	90:1	90:1	110:1	110:1	110:1	110:1	
Nominal motor power	-	30***	3	-	-	30***	3	-	-	30***	3	-	W
Motor voltage	-	24	12	24*	-	24	12	24*	-	24	12	24*	V
Weight	0.42	0.94	0.94	0.96	1.36	1.88	1.88	1.90	2.24	2.76	2.76	2.78	kg
Body material	Al	Al	Al	Al	Al	Al	Al	Al	Al	Al	Al	Al	
Recommended motor controller		C-843, C-862	C-843, C-862	C-600, C-630		C-843, C-862	C-843, C-862	C-600, C-630		C-843, C-862	C-843, C-862	C-600, C-630	

C-815.38 motor cable included: 3 m, sub-D, 15/15 pin (m/f).

* 2-phase stepper, 24 V chopper voltage, max. 0.8 A / phase, 20,000 microsteps with C-600 or C-630 controller

** CW: Clockwise; CCW: Counter Clockwise

*** ActiveDrive™ (integrated PWM servo-amplifier)

See page 7-106 for notes and explanations.

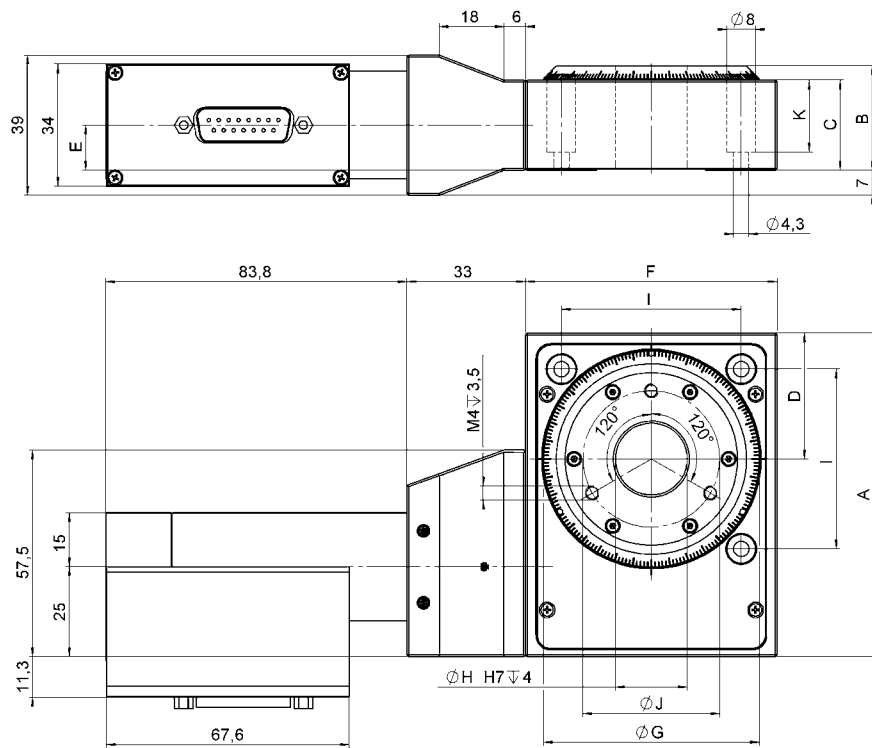

mm	M-060.DG	M-061.DG	M-062.DG
A	90	130	150
B	29	34	42
C	25	30	38
D	35	55	65
E	12,5	15	21,5
F	70	110	130
G	60	100	120
H	20	35	45
I	50	90	110
J	38	50	60
K	20	20	28

M-060.DG, M-061.DG, M-062.DG rotation stages, dimensions (in mm)

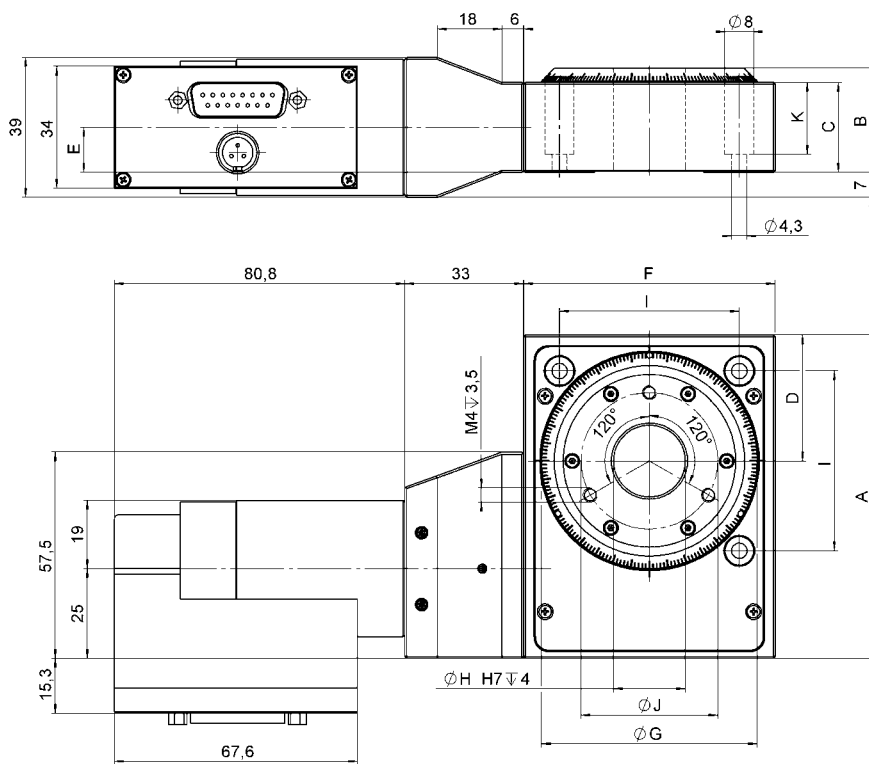

mm	M-060.PD	M-061.PD	M-062.PD
A	90	130	150
B	29	34	42
C	25	30	38
D	35	55	65
E	12,5	15	21,5
F	70	110	130
G	60	100	120
H	20	35	45
I	50	90	110
J	38	50	60
K	20	20	28

M-060.PD, M-061.PD, M-062.PD rotation stages, dimensions (in mm)