

C-136 • C-150

DC-Motor / Encoder Drives

>> Click <http://www.pi.ws/fwd/Motion-Control> for the Latest Specs on these Products



C-136.10

■ Cable Length up to 30 m Possible (Differential Encoder Line Drivers)

■ ActiveDrive™ Concept

The C-136.10 and C-150.PD are compact, closed-loop, DC-servo-motor drives. Model C-136.10 is equipped with a 29.6:1 reduction gearhead and a 3 W motor, while model C-150.PD incorporates the ActiveDrive™ system.

ActiveDrive™

This innovative design features a high-efficiency PWM servo-amplifier integrated in the motor casing, providing several decisive advantages:

■ Increased efficiency by eliminating power losses between the amplifier and motor

■ Reduced cost of ownership and improved reliability because no external driver is required

■ Elimination of PWM amplifier noise radiation by mounting the amplifier and motor together in the same electrically shielded case

A power supply providing 2.2 A at 24 V (for the ActiveDrive™) is included with the C-150.PD.

Integrated Line Drivers

Both motors are equipped with differential line drivers on the encoder lines, allowing cable lengths up to 10 m between the motor and controller.

Technical Data

Models	C-136.10	C-150.PD	Units
Encoder resolution	2000	4000	counts/rev.
Motor shaft resolution	0.006	0.09	°/count
V _{max} (unloaded)	3.3 (backlash-free gearhead: (28/12) ⁴ :1 ≈ 29.6:1)	100 (direct)	rev./s
Operating voltage	12	24*	V
Average motor power	3	30	W
Average torque	10	6	Ncm
Weight	0.29	0.45	kg
Recommended motor controller	C-843, C-848, C-862	C-843, C-848, C-862	

* ActiveDrive™ (integrated PWM servo-amplifier), external 24 V P/S included

Ordering Information

C-136.10
DC Motor/Encoder/
Gearhead Drive, 3 W

C-150.PD
ActiveDrive™ DC Motor/
Encoder, 30 W, Includes 24 V P/S

Ask about custom designs!

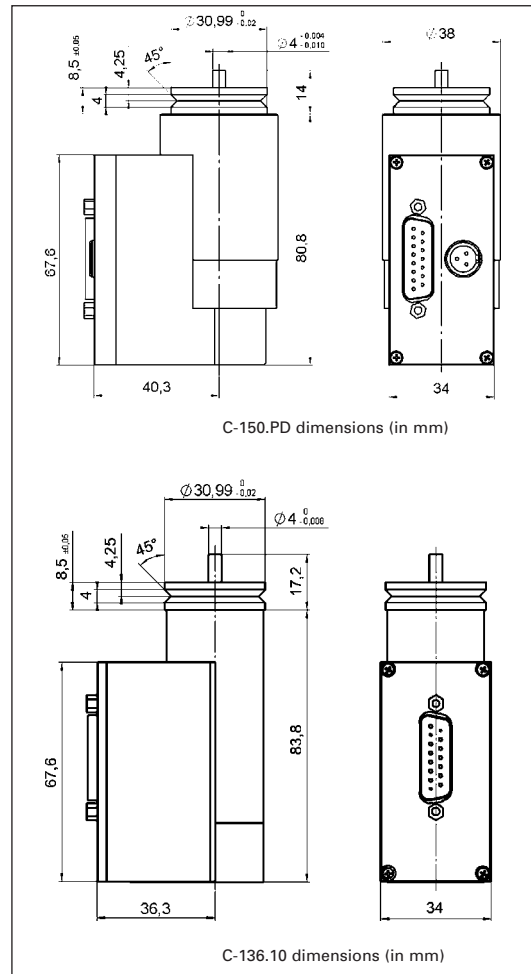

C-150.PD dimensions (in mm)

C-136.10 dimensions (in mm)

Piezo Actuators

Nanopositioning & Scanning Systems

Active Optics / Steering Mirrors

Tutorial: Piezo-electrics in Positioning

Capacitive Position Sensors

Piezo Drivers & Nanopositioning Controllers

Hexapods / Micropositioning

Photonics Alignment Solutions

Motion Controllers

Ceramic Linear Motors & Stages

Index

Application Examples

■ Precision drive for linear and rotary positioners